

PHILIPS



MAT 219

Service Manual

15 MHz. Dual channel oscilloscope PM 3207

9444 032 07..1



IMPORTANT

In correspondence concerning this instrument, please quote the type number and serial number as given on the type plate.

Note: The design of this instrument is subject to continuous development and improvement. Consequently, this instrument may incorporate minor changes in detail from the information contained in this manual.

CONTENTS

1.	Characteristics	4
1.1.	Environmental capabilities	6
1.2.	Optional accessories	6
2.	Circuit descriptions	7
2.1.	Description of the block diagram	7
2.1.1.	Vertical deflection	7
2.1.2.	Triggering and horizontal deflection	12
2.1.3.	CRT Display section	12
2.1.4.	Power supply	13
2.2.	Circuit description	14
2.2.1.	Vertical deflection	14
2.2.2.	Horizontal deflection and time base	18
2.2.3.	CRT Display section	22
2.2.4.	Power supply	22
3.	Dismantling the instrument	23
3.1.	Precautions	23
3.2.	Removing the top-cover	23
3.2.1.	Remounting the top-cover	23
3.3.	Removing the power supply-unit	23
3.3.1.	Remounting the power supply-unit	24
3.4.	Removing the front-cover with control unit	24
3.5.	Replacing the CRT	24
4.	Checking and adjusting	28
4.1.	General	28
4.2.	Table of adjustings	30
4.3.	Survey of measuring points	32
4.4.	Component location list	36
5.	Parts lists and diagrams	38
5.1.	Adaption of mains (line) voltage	51

1. CHARACTERISTICS

This instrument has been designed and tested in accordance with IEC Publication 348 for Class 2 instruments and has been supplied in a safe condition. The present Service Manual contains information and warnings that shall be followed by the purchaser to ensure safe operation and to retain the instrument in a safe condition.

This specification is valid after the instrument has warmed up for 15 minutes. Properties expressed in numerical values with tolerances stated, are guaranteed by the manufacturer. Numerical values without tolerances are typical and represent the characteristics of an average instrument.

C.R.T.

Type	: Philips D 14-250 GH rectangular tube with 1,5kV accelerating voltage.
Screen type	: P31 (GH) phosphor standard P 7 (GM) phosphor optional
Useful screen area	: 8 X 10 div. of 1 cm
Graticule	: External graticule with centimeter division and 2 mm divisions along the central axes.

VERTICAL OR Y-AXIS

Response	: DC: 0 Hz ... 15 MHz (-3 dB) AC: 10 Hz ... 15 MHz (-3 dB)
Risetime	: 23 ns
Deflection coefficient	: 5mV ... 10V/div. calibrated steps, 1-2-5 sequence.
Accuracy	: $\pm 5\%$
Display modes	: A A \pm B A & \pm B \pm B
Input impedance	: 1 MOhm // 35pF
Input coupling	: AC, DC
Maximum input voltage	: 400 V (DC + AC _{pk})

HORIZONTAL OR X-AXIS

Horizontal display modes	: - Time base - X-Y operation with X deflection via A-input
--------------------------	--

HORIZONTAL AMPLIFIER

Response	: DC: 0 Hz ... 2 MHz (-3 dB)
Deflection coefficients	: See Y-axes
Phase error	: 3° at 10 kHz

TIMEBASE

Time coefficients	: 0.2s/div..0.5 μs/div. in 2 X 9 calibrated steps in 1-2-5 sequence. X 5 magnifier extends max. sweep rate to 100 ns/div.
Accuracy	: ± 5% Additional error for magnifier: ± 2%

TRIGGERING

Trigger source	: Internal: A or B External
Trigger coupling	: AC TV
Slope	: + or -
Trigger sensitivity	: Internal : 0.75 div. at 100 kHz External : 0.75V at 100 kHz
Automatic trigger	: Adjustable between peaks of signal
External trigger input impedance	: 1 MOhm // 35pF
Max. allowable input volt.	: 400V (DC + AC _{pk})

CALIBRATION

Signal available for probe adjustment

POWER

Line voltage and freq.	: 110, 220 or 240V AC ± 10% 45 ... 66 Hz
Power consumption	: 25W at nominal line voltage. The insulation between PM 3207 and line fulfills the safety requirements of IEC 348 for Class II instruments.

1.1. ENVIRONMENTAL CAPABILITIES

The environmental data are valid only if the instrument is checked in accordance with the official checking procedure. Details on these procedures and failure criteria are supplied on request by the PHILIPS organisation in your country, or by N.V. PHILIPS' GLOEILAMPEN-FABRIEKEN, TEST AND MEASURING INSTRUMENTS DEPARTMENT, EINDHOVEN, HOLLAND.

Ambient temperature	: Rated range of use: + 5°C ... + 40°C Limits for operating: - 10°C ... + 45°C Storage and transport: - 40°C ... + 70°C
Altitude	: Operating: to 5000m (15000 ft) Non-operating: to 15000m (45000 ft)
Humidity	: 21 days cyclic damp heat 25°C - 40°C R.H. 95%
Shock	: 30 g: half sine wave shock of 11ms duration: 3 shocks per direction for a total of 12 shocks
Vibration	: 3 g vibrations in three directions with a maximum of 15 min. per direction; 10 minutes with a frequency of 15-25 Hz and amplitude of 1mm p-p. Unit mounted on vibration table without shock absorbing material.
Recovery time	: Operates within 60 minutes coming from -10°C soak, going into 60% relative humidity at + 20°C room conditions.
Dimensions and weight	: (wxhxd) 297 x 129 x 297mm exclusive handle 330 x 138 x 450mm inclusive handle 4,7 kg (16.5 lb)
Accessories supplied	: Operating manual

1.2. OPTIONAL ACCESSORIES

PM 9326	Passive probe 1 : 1/10 : 1 (1.1m)
PM 9327	Passive probe 1 : 1/10 : 1 (2.1m)
PM 9328	Set of two passive probes 1 : 1/10 : 1
PM 8921	Passive probe 1 : 1 (1.5m)
PM 8921 L	Passive probe 1 : 1 (2.5m)
PM 8925	Passive probe 10 : 1; 11pF (1.5m)
PM 8925 L	Passive probe 10 : 1; 14pF (2.5m)
PM 8932	Passive probe 100 : 1 max. voltage 2000V; 1.2pF (1.5m)
PM 9355	Current probe; 1,2 Hz ... 70 MHz
PM 9366	Collapsible viewing hood
PM 8980	Closed, long type viewing hood

2. CIRCUIT DESCRIPTIONS

2.1. Description of the block diagram

The circuit is located on printed-circuit boards and is sub-divided into the following parts:

- vertical amplifier channels A and B
- final vertical amplifier and Z amplifier
- time-base and horizontal amplifier
- c.r.t. circuits
- power supply unit

The block diagram of the PM 3207 is given in Fig. A.

The sub-divisions of the diagram do not necessarily relate to the circuit areas of the printed-circuit boards.

2.1.1. Vertical Deflection

As the A and B channels are almost identical, only channel A is described.

The signal at the input socket is applied either directly or via a d.c. blocking capacitor, depending on the position of the AC/DC coupling switch to the high-impedance A ATTENUATOR stage. This stage incorporates the 1, 10 and 100 attenuation coefficients, which are selected by the A AMPL/DIV switch. The A ATTENUATOR is followed by an IMPEDANCE CONVERTER and PREAMPLIFIER, which provides the following functions:

- the 1-2-5 attenuator sequence in conjunction with the basic attenuation coefficients
- an adjustment of DC BALANCE
- a 10 times gain increase for the two most sensitive AMPL/DIV ranges.
- a GAIN $\times 10$ ADJUSTMENT control
- a GAIN $\times 1$ ADJUSTMENT (NORMAL/INVERT function for channel B).

The PREAMPLIFIER in channel A has three outputs, one of which feeds the TRIGGER PICK-OFF amplifier.

Another output feeds the channel A SWITCHED AMPLIFIER stage via a transistor BUFFER. An additional output provides the signal for the X via A mode.

The signal is fed via the X-deflection selector to the final X-amplifier.

Depending on the command signal from the CHANNEL SELECTOR, the SWITCHED AMPLIFIER routes the buffered PREAMPLIFIER signal through to the FINAL Y AMPLIFIER. The FINAL Y AMPLIFIER feeds the Y1 and Y2 vertical deflection plates of the CATHODE RAY TUBE (C.R.T.). The CHANNEL SELECTOR signals are generated by a multivibrator controlled by logic gates from the front-panel channel selection switches A-OFF, B-OFF, A&B, ADD and μ s/ms (ALT./CHOPP.)

For the μ s (ALT) mode, an input signal derived from the time-base is used for switching purposes. The following modes are possible:

- Single channel operation: one channel is permanently switched through to the final Y amplifier while the other channel is blocked.
- Dual-channel operation in μ s (ALT) mode: the final Y channel input is switched from one channel to the other at the end of each time-base sweep.
- Dual-channel operation in ms (CHOP) mode: the final Y amplifier input is switched from one channel to the other at a frequency of 200 KHz.
- ADD mode: both channels are simultaneously switched through to the final Y amplifier and addition of both channels takes place.
- Subtract mode (B channel INVERT selected): both channels are simultaneously switched through to the final Y amplifier as in the ADD mode, but channel B is inverted.

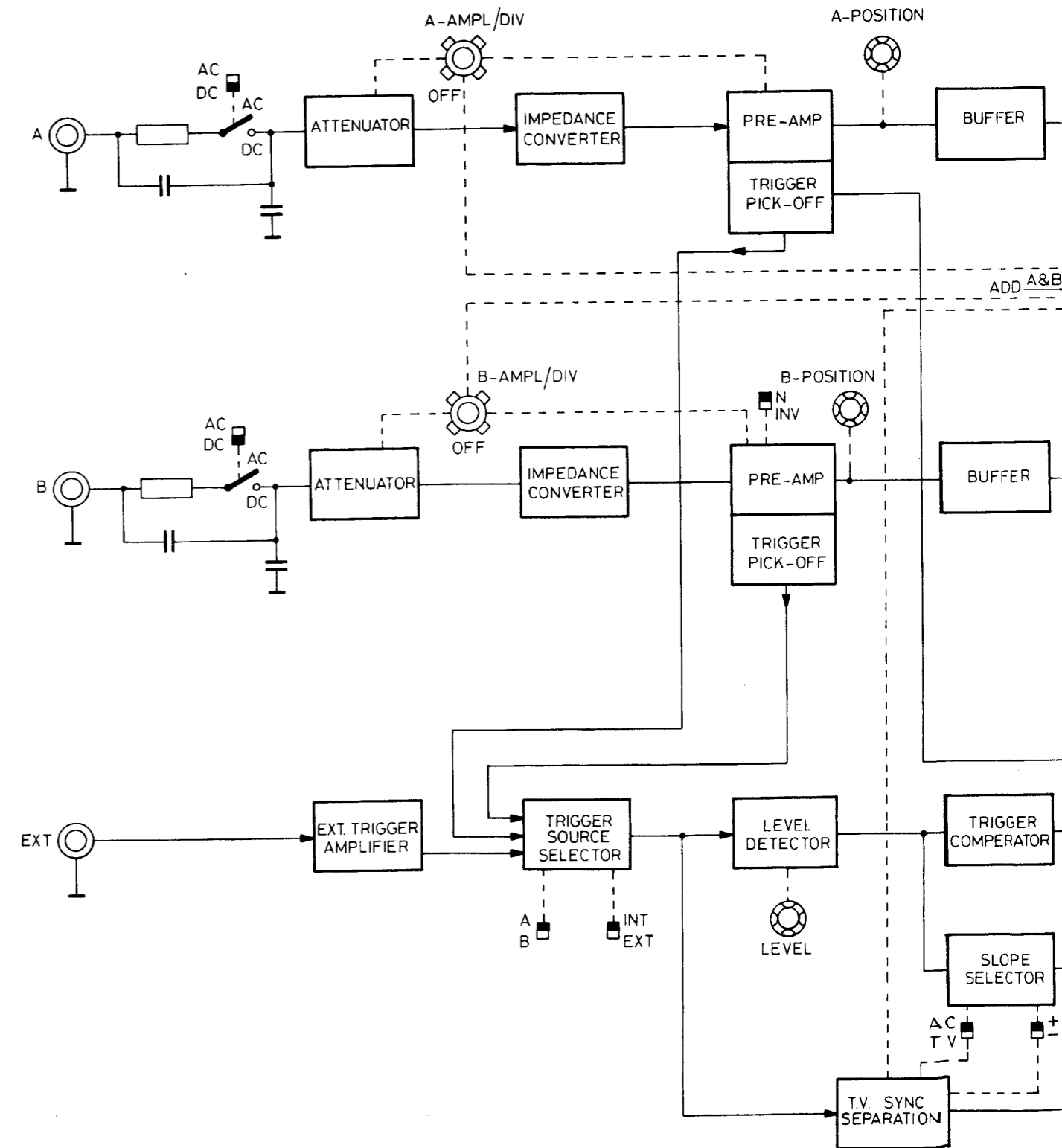

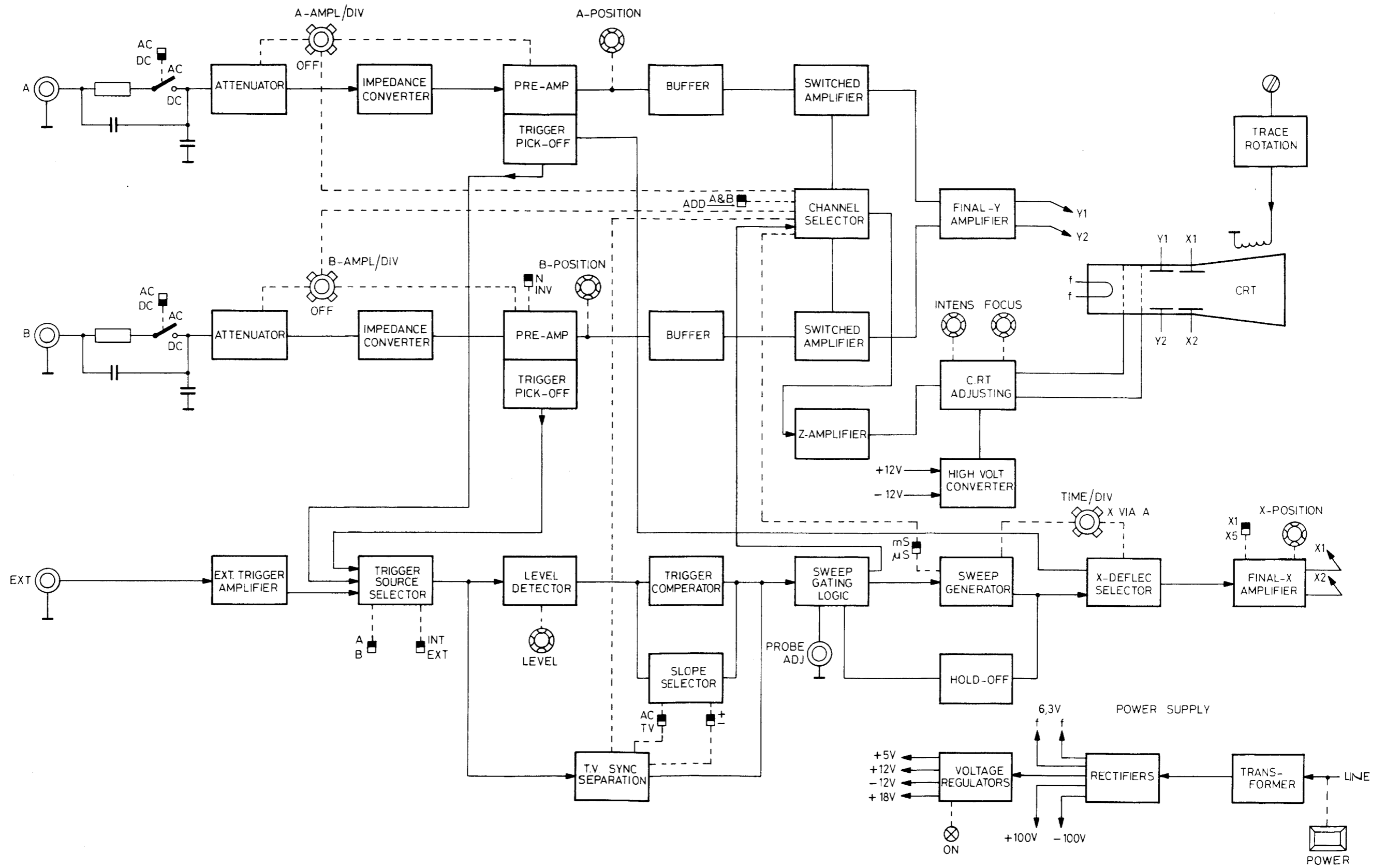

Fig. A. Block diagram

MAT 168

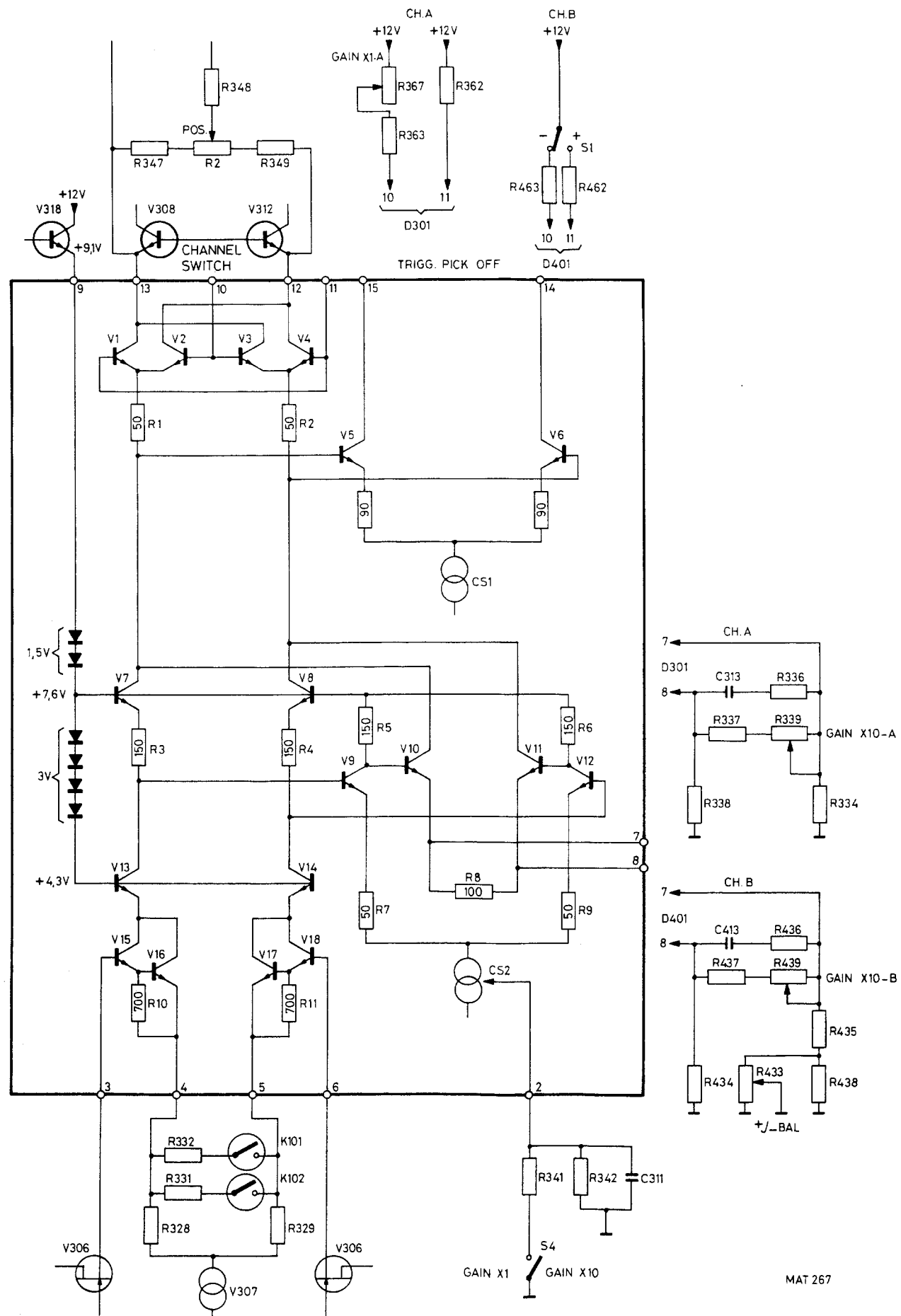

Fig. B. Simplified circuit diagram of D301/D401

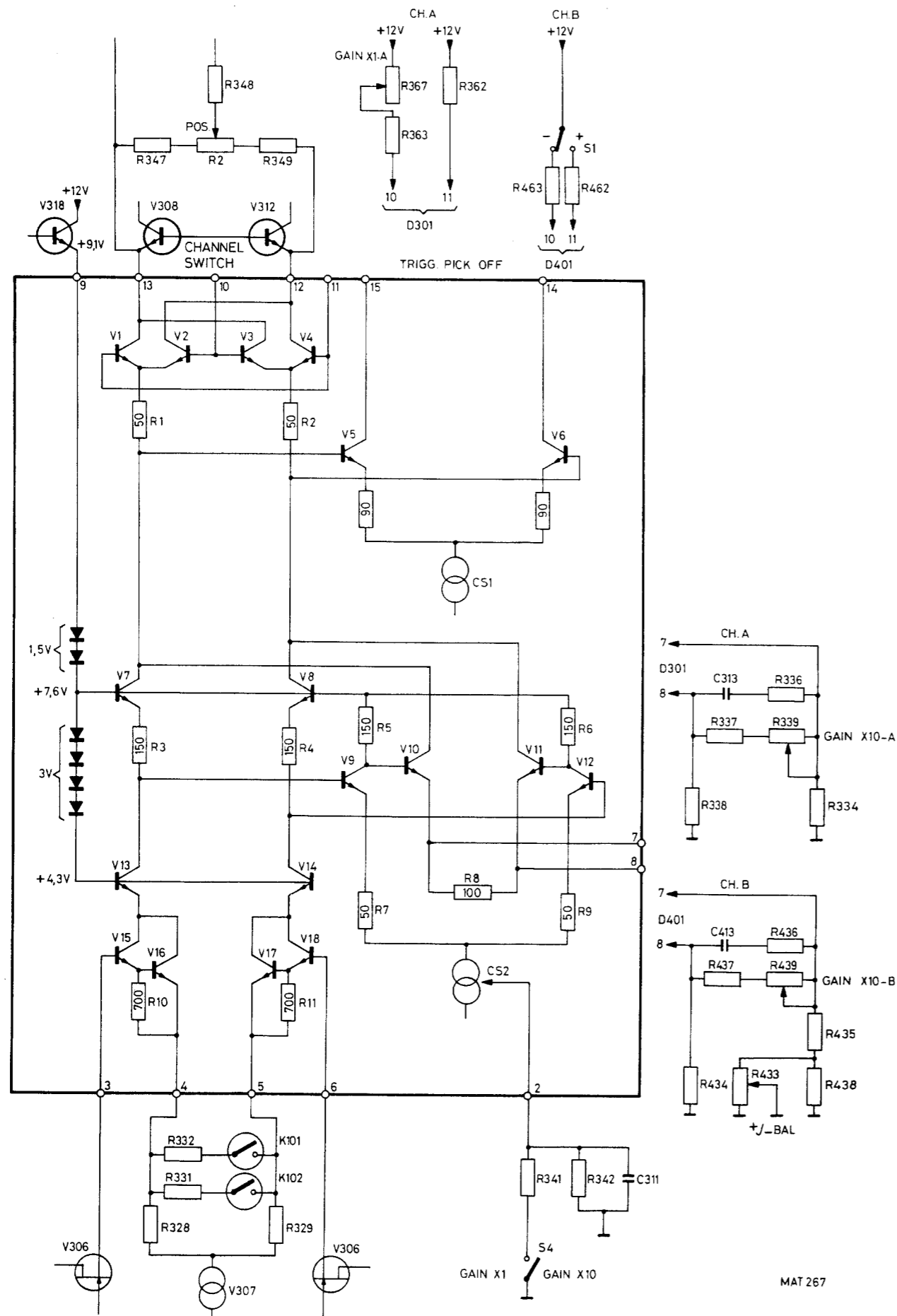

Fig. B. Simplified circuit diagram of D301/D401

2.1.2. Triggering and Horizontal Deflection

The signal source required for time-base triggering is selected by the TRIGGER SOURCE SELECTOR under the command of the front-panel trigger selector switches.

The trigger sources are available from the following:

- The channel A or B TRIGGER PICK-OFF amplifiers, which are activated by the A and B switches.
- The EXTERNAL TRIGGER AMPLIFIER in order to trigger on a signal applied to the external input X5; activated by the EXT switch.

The TRIGGER SOURCE SELECTOR output is applied to the LEVEL DETECTOR. The output of the LEVEL DETECTOR feeds the TRIGGER COMPARATOR, which enables the selected level to be compared with the incoming trigger signal to determine the level at which the time-base starts. With switch AC/TV in TV position the TRIGGER SOURCE SELECTOR OUTPUT is also fed to the TV SYNC. SEPARATION.

In case of positive video signal the +/- switch should be in + position.

The TV SYNC SEPARATOR stage allows triggering on TV frame pulses (ms position of ms/ μ s-switch) or TV line pulses (μ s position of ms/ μ s-switch).

The output of the TRIGGER COMPARATOR feeds the SWEEP GATING LOGIC.

Depending on the position of the +/- switch the SWEEP GENERATOR starts on the positive- or negative going slope of the input signal. With the AC/TV switch in TV position the TV SYNC SEPARATION output is applied to the SWEEP GATING LOGIC and the TRIGGER COMPARTOR-output is blocked.

The HOLD-OFF circuit prevents the SWEEP GENERATOR from responding to a trigger command before the time-base capacitors are fully discharged.

The SWEEP GATING logic, in addition to feeding the SWEEP GENERATOR, also feeds the CHANNEL SELECTOR in order to control the ALTERNATE vertical display mode switching. An output also controls the Z AMPLIFIER in order to blank the trace during the flyback of the time-base.

The SWEEP GENERATOR produces the sawtooth waveform that is used for horizontal deflection. The time-base sweep time can be adjusted by the step control TIME/DIV.

The X DEFLECTION SELECTOR enables the input to the FINAL Y AMPLIFIER to be selected by diode switching networks. Normally, the internal time-base produced by the SWEEP GENERATOR is routed to the FINAL X AMPLIFIER, but in the X via A mode, an output signal from TRIGGER PICK-OFF the channel A is selected.

The FINAL X AMPLIFIER, which drives the X1, X2, horizontal deflection plates of the C.R.T., has an X-POSITION control potentiometer. In addition, the stage has a X5 magnifier switch facility, which increases the horizontal gain by a factor of 5.

2.1.3. CRT Display Section

The Z AMPLIFIER receives an input blanking pulse which originates in the channel selector multivibrator and the sweepgating logic. Blanking of the trace takes place during flyback of the time-base and also in the chopped mode during switching from one channel to the other. The INTENS control determines the d.c. level fed to the cathode of the C.R.T. The output of the Z AMPLIFIER is capacitively coupled to the CRT control electrodes.

A HIGH-VOLTAGE CONVERTER provides the final anode potential (-1.5 kV) of the CRT. The TRACE ROTATION circuit, operated by a rear-panel preset control, enables adjustment of the sense and strength of current through the trace-rotation coil of the CRT. This allows alignment of the time-base with the horizontal graticule lines.

2.1.4. Power Supply

The mains supply is transformed by means of a double-isolated TRANSFORMER and rectified to give d.c. supplies of +100V and -100V.

A VOLTAGE REGULATOR stage comprising four integrated circuits provides low-voltage d.c. outputs of +5V, +12V, -12V and +18V to feed the various stages of the oscilloscope.

A 6.3V a.c. secondary winding of the mains transformer supplies the filament of the CRT.

2.2. Circuit Description

2.2.1. Vertical deflection

As channels A and B are identical, only channel A is described.

INPUT COUPLING STAGE

In the DC position (reed relay K105 energised), the signal applied to input socket X2 is fed to the high impedance attenuator via R301 and R302.

In the AC position (K105 released), the signal applied to input socket X2 is fed to the high impedance attenuator via R301 and d.c. blocking capacitor C301.

Resistor R302 discharges C301 when switch S8 is changed from the AC to the DC position.

HIGH IMPEDANCE ATTENUATOR

This section of the circuit comprises the 1, 10 and 100 times attenuator.

The 100 times attenuator is active in the 10, 5 and 2V/DIV attenuator switch (S4) positions; i.e. the output signal from the coupling stage is applied via K104 contact to the attenuator section comprising R311, R312, R314 and parallel capacitors. The signal, reduced by an attenuator factor of 100, is fed via K107 contact to the PREAMPLIFIER.

The 10 times attenuator is active in the 1, 0.5 and 0.2V/DIV attenuator switch (S4) positions; i.e. the output signal from the coupling stage is applied via K104 contact to the attenuator section comprising R308, R309, R313 and parallel capacitors. The signal, reduced by an attenuation factor of 10, is fed via K103 contact to the PREAMPLIFIER.

The 1x attenuator is active in the 100, 50, 20, 10 and 5mV/DIV positions of S4; i.e. the output signal from the coupling stage is applied via K106 contact, R306, R307 and parallel capacitor C306 direct to the PREAMPLIFIER.

Resistors R306, R307 serve to limit the current to the PREAMPLIFIER if high amplitude signals are applied to the input of the instrument.

In conjunction with these three basic attenuator coefficients, switched by reed relays K106 (5mV - 0.1V), K104 (0.2V - 1V) and K107 (2V - 10V), the 1-2-5 attenuator sequence of adjacent ranges is provided by relays K101 and K102.

PREAMPLIFIER (V306, V307, V318, D301)

The output of the HIGH IMPEDANCE ATTENUATOR is connected via resistor R315 to the input of a symmetrical impedance converter consisting of two matched FETs V306 in source follower configuration.

The DC BALANCE of this stage is adjusted by potentiometer R318.

Diode V304 protects the FET input against excessive negative voltages.

The main part of the preamplifier is formed by integrated circuit D301, a simplified diagram of which is given in Fig. B, together with its associated discrete components.

The preamplifier operates as follows:

The source signals from V306 are fed via pins 3 and 6 of D301 (testpoints M1, M2 respectively) to the bases of the input stage V15/V16 and V18/V17. The emitters of transistors V16 and V17 are connected via pins 4 and 5 to a resistor network R328, R329, R331, R332 that can be switched by reed relay contacts K101 and K102.

- Resistors R328, R329 are always in circuit (K101, K102 released) and determine the amplification of the input stage of D301 in the attenuator switch positions 10V, 1V, 100mV and 10mV/DIV.
- When contact K102 closes, R331 is switched into circuit and the amplification of the input stage of D301 increases 2x. This occurs in the attenuator switch positions 5V, 0.5V, 50mV and 5mV/DIV.
- When contact K101 closes, R332 is switched into circuit and the amplification of the input stage of D301 increases 5x. This occurs in the attenuator switch positions 2V, 0.2V, and 20mV/DIV.

In D301, the collector current of input stages V15/V16 and V18/V17 flows through the transistor V13 and V14. These transistors operate in a common-base configuration and their bases are kept at a fixed potential of +4.6V when pin 9 is held at a supply voltage of +9.1V by V318 and its associated components.

The collector current of V13 and V14 flows via the 150 ohm resistors R3 and R4 to transistors V7 and V8. These transistors also operate in common-base configuration, and their bases are kept at a fixed potential of +7.6V when pin 9 is held at a supply voltage of +9.1V.

A 10x gain increase for the two most sensitive attenuator switch positions occurs when pin 2 receives a +2.5V input via V102, R341 and R342.

In D301, current source CS2 is activated when pin 2 is positive and therefore the amplifier stage V9/V10 and V12/V11 operates. This stage receives the signal on R3 and R4 on its inputs, and gives a collector current equal to nine times that received from V7 and V8. The sum of both collector currents gives a gain increase of ten times.

The GAIN $\times 10$ ADJUSTMENT is achieved by potentiometer R339, incorporated in the network connected to pins 7 and 8 of D301, which are connected internally to the emitters of V10 and V11 in the nine times amplifier stage.

In the channel B, this circuit also incorporates the channel B +/- BALANCE preset R433.

The collector current of V7 and V8 and eventually (GAIN $\times 10$ mode) V10 and V11 flows via R1 and R2 through the emitters of a multiplier stage, V1/V2 and V3/V4. In channel A the multiplier stage is used for GAIN $\times 1$ ADJUSTMENT; in channel B it is used for the +/- function.

In channel B, the +/- functions as follows:

+ mode: pin 10 is floating and pin 11 is connected via R462 and S1 to +12V. In this mode, V1 and V4 are conductive, V2 and V3 are non-conductive.
The emitter current of V1 appears on pin 13 and the emitter current of V4 appears on pin 12.

- mode: pin 11 is floating and pin 10 is connected via R463 and S1 to +12V. In this mode, V1 and V4 are non-conductive, V2 and V3 are conductive.
The emitter currents of V2 and V3 appear on pins 12 and 13 respectively.

In channel A, V1, V2, V3 and V4 all conduct to some degree. The gain can be adjusted by varying the conductivity of V1 and V4 using the base circuit R363 and potentiometer R367 connected to pin 10.

The output pins of D301, pins 13 and 12, are connected to the emitters of V308 and V312 in the BUFFER.

Note that in the $\times 1$ GAIN position the current applied to pins 4 and 5 is equivalent to the output current at pins 12 and 13.

Transistors V5, V6 and the current source CS1 are used to drive the trigger pick-off amplifiers via pin 15 and pin 14. For X-deflection pin 14 and 15 of D301 are outputs which can drive the X-amplifier via the X-deflection selector.

BUFFER (V308, V312)

Transistors V308 and V312 connected in grounded-base configuration provide a buffer stage between the output of the PREAMPLIFIER and the CHANNEL SWITCH.

CHANNEL SWITCH (V310, V309, V315, V311)

Depending on the output signal from the channel flip-flop D553, this circuit is able to switch the signal on pins 13 and 12 of D301, via the buffer, through to the final Y amplifier. When transistors V309 and V311 are held on they block the channel A switching transistors V310 and V315.

The switching modes are as follows:

Channel A switched off:

Flip-flop D553 output 9 is at logic 0, consequently, output 10 of gate D551 is at logic 1. The bases of transistors V309 and V311 are therefore positive and these transistors conduct, thereby switching off the channel A switching transistors V310 and V315.

Channel A switched on:

Flip-flop D553 output 9 is at logic 1, consequently, output 10 of gate D551 is at logic 0. The bases of transistors V309 and V311 are therefore switched off and so channel A switching transistors V310 and V315 are switched on.

FINAL AMPLIFIER (V509, V507, V512, V501 ... V519)

The input stage of the final Y amplifier consists of a series feedback stage with transistor V507 balanced by V512. This stage has adjustment points for channel B gain adjustment (R509) and square-wave compensation (C503).

Note that as R509 is common to both channels, channel A gain control R367 must be re-adjusted after any adjustment of R509.

Transistor V509 serves as a constant current source for the emitters of V507 and V512.

The output stage of the final Y amplifier consists of V501, V502, V506, V508. These transistors drive the Y2 deflection plate and are balanced by transistors V513, V514, V517, V519, which drive deflection plate Y1. In order to increase stability, the deflection plates are driven via resistors R529 and R531.

In the Y2 plate drive section, V501, V502 function as a current source.

Transistors V506 and V508 form a shunt feedback stage. Two transistors are used in each case so as not to exceed the maximum permissible current and voltage limits of the transistors.

In the Y1 plate drive section, V517 and V519 are the current source and V513 and V514 are the shunt feedback stage.

CHANNEL FLIP-FLOP AND LOGIC CIRCUITS (D551, D552, D553)

The logic circuits used in this unit can have two logic output levels:

a low level or logic 0 between 0V and 0.8V, and a high level or logic 1 between 2V and 5V.

The unit has two outputs gates D551/8/9/10 and D551/12/11/13 which, when active, provide a logic 0 output to switch channel A and channel B respectively.

These gates are controlled by the outputs of multivibrator D553 under the command of the various switching modes, CH. A ON/OFF, CH. B ON/OFF, ADD and the ALT/CHOP modes selected by the μ s/ms positions of the time-base.

- CH.A ON (A AMP/DIV switch S4): the positive output on switch S5-1 via R551 gives logic 1 on input 10 of NAND gate D552. As the two inputs to gate D551/5/6/4 are at logic 0, its output, and hence input 9 of D552, is at logic 1. Therefore, the input on pin 10 of flip-flop D553 is at logic 0 and the output on pin 9 is at logic 1. This provides a logic 1 to input 8 of D551 to give a logic 0 output on pin 10 (testpoint M10) to switch the A channel through.
- CH.B ON (B AMP/DIV switch S5): the positive output on switch S4-1 via R552 gives a logic 1 on input 5 of gate D551, which produces a logic 0 on output 4, and hence a logic 0 on input 13 of flip-flop D553. This gives a logic 1 on output pin 8, which results in a logic 0 on output pin 13 of D551 (testpoint M11) to switch the B channel through.
- ADD mode (S9 to ADD, S4 and S5 to ON): the +12V on S9 is fed via diode V557 and R563 to provide a logic 1 on inputs 9 and 11 of gates D551. The resulting logic 0s on outputs 10 and 13 enable both channels A and B together to provide a signal to the final Y amplifier that is the sum of the two signals.
(Note: with CH.B INVERT selected, the resultant signal is the difference of the two channel input signals).

CH.A ON, CH.B ON (Switches S4 and S5 to ON):

Switch S2 in μ s position (ALT mode): the +12V on S2 is fed via diode V552 and resistor R558 to provide a logic 1 on input 3 of gate D551. The logic 0 on output pin 1 disables the CHOP oscillator D552/1,2,3 and the output, D552-3, is at logic 1.

Output 5 of flip-flop D704, connected to input 4 of flip-flop D553, is at logic 0 during the time-base sweep and at logic 1 during the hold-off period. Thus input 5 of NAND gate D552 is at logic 1 during the time-base sweep and at logic 0 during the hold-off period. Therefore, the CLOCK input (pin 11) of flip-flop D553 goes from logic 0 to logic 1 at the end of every sweep and changes the state of the flip-flop. In this way, the display switches Alternately between the channels.

Switch S2 in ms position (CHOP mode):

Without the +12V on S2, diode V552 is blocked and input 3 of gate D551 is at logic 0. The logic 1 on output pin 1 enables the CHOP oscillator D552/1,2,3. This oscillator is a NAND-Schmitt-trigger with an RC feedback loop, which produces a 200 kHz square-wave signal on its output (pin 3). This is at logic 1 if the oscillator is switched off in single channel or ALT mode.

The signal (testpoint M12), applied via R573 to the base of transistor V573 in the Z amplifier, is used to blank the display when switching over between the A and B channels.

The oscillator output is fed to input pin 4 of NAND gate D552. During the time-base sweep the other input (pin 5) of D552 is at logic 1, therefore the inverted chopper pulses are fed to the CLOCK input (pin 11) of flip-flop D553. As both the Clear and Preset inputs of the flip-flop are at logic 1 (switches S4 and S5 ON) then they are inactive. Therefore, due to the feedback connection between output pin 8 and pin 12 the flip-flop changes state at every clock pulse. In this way, via output gates D551/8,9,10 and D551/12,11,13, the display switches between the A and B channels at a frequency of 200 kHz.

	D551/3	D551/2	D552/1	D553/13 CLEAR	D553/9 OUTPUT	D553/8 INV. OUTPUT
A on / B off	-	1	0	1	1	0
B on / A off	-	1	0	0	0	1
<u>A and B on:</u>						
- in ALT mode (μ s)	1	0	0	1	1/0	0/1
				(state changes at end of every sweep)		
- in CHOP mode (ms)	0	0	1	1	1/0	0/1
				(state changes at chopper frequency)		

2.2.2. Horizontal Deflection and Time-Base

CH.A TRIGGER PICK-OFF (V313, V314, V317)

The trigger signal current is picked off from differential output pins 14 and 15 of D301 by means of transistors V313 and V317. When channel A triggering is selected (S11 to A and S13 to INT), the collector output of V313 is applied via diode V603 in the trigger source selector to the base of transistor V607.

The B channel pick-off and EXT trigger input are inhibited by the -12V switched supply that blocks diodes V604 and V606.

The channel A pick-off stage also has an output from V317 collector that is used to drive the horizontal amplifier in the X via A mode.

Transistor V721 shunt feedback stage is used for this amplifier stage, the collector of V721 feeding the X deflection selector. Transistor V722 and relevant components supply a constant voltage to the emitter connection. The emitter currents for V313 and V317 are derived via the constant-current source transistor V314.

CH.B TRIGGER PICK-OFF (V413, V414, V417)

The trigger signal current is picked off from pins 14 and 15 of D401 by transistor V413 balanced by V414 with V417 provided the constant-current source. Unlike channel A, channel B has no pick-off from V414 collector to the horizontal amplifier.

The collector signal from V413 is routed via diode V604 in the trigger source selector to the base of transistor V607. The A channel pick-off and the EXT trigger input are inhibited by the -12V switched supply that blocks diodes V603 and V606.

EXTERNAL TRIGGER AMPLIFIER (V613, V614, V616, V617)

The signal applied to the external trigger input socket (X5) is attenuated by a voltage divider network R610/C601, R600/C602 in the base circuit of emitter-followers V613 and V614 connected in cascade. Capacitor C603 serves for d.c. blocking and diode V612 protects transistor V613 against excessive positive input voltage swings.

The emitter of V614 is coupled via C604 to the series feedback stage V616/V617. The collector current of V617 is connected via diode V606 to the base of transistor V607. The A and B internal pick-offs are inhibited in the EXT position of S13 by the -12V switched supply via diodes V601 and V602 that blocks V603 and V604 respectively.

TRIGGER SOURCE SELECTOR AMPLIFIER (V607, V611)

The diode networks referred to in the foregoing descriptions of the trigger pick-offs and the external trigger amplifier are all associated with the trigger source selector switches S11 and S13, and the method of selecting each trigger source has been described under these headings. The selected trigger signal to the base of transistor V607 is amplified and fed to emitter follower V611. Electrolytic capacitor C606 connects this signal to testpoint M13 (Topdetector, comparator and TV circuitry).

LEVEL DETECTOR (D601)

The LEVEL voltage control R5 permits variation of the trigger level of the signal detected by this circuit.

The negative excursions of the trigger signal are passed by diode V623 and integrated by electrolytic C608 to provide the input to pin 10 of operational amplifier D601.

The positive excursions of the trigger signal are passed by diode V624 and integrated by electrolytic C609 to provide the input to pin 3 of operational amplifier D601.

The two operational outputs are fed to opposite ends of LEVEL control R5. The selected trigger level is fed to input 12 of operational amplifier D601, the output of which feeds the comparator.

COMPARATOR (V627, V629, V628)

SWEEP GATING LOGIC (D701, D702)

The trigger level selected by the LEVEL control is applied to the base of V627, which together with V629 forms a differential amplifier comparator circuit. The trigger signal from testpoint M13 is fed directly to the base of V629. When this trigger signal exceeds the signal from the LEVEL control, V627 conducts less and the collector current decreases so the voltage of the shunt feed-back stage V628 increases.

This signal is applied to input 1 of NAND Schmitt-trigger D701 in the sweep-gating logic, and if S14 is in AC position the inverted signal appears at D701 pin 3. With the +/- switch S12 in "+" position, output 3 of D702 is logic 2 and the exclusive-or D702 (output 6) inverts the signal applied to input 5, so triggering is effected on the positive slope.

If switch S12 is in "-" position the exclusive-or D702 input 4 is at logic 0 so the signal applied to input 5 appears at pin 6.

Now triggering is effected on the negative slope.

T.V. SLOPE SELECTOR (V618, V619)

The output signal from the trigger source selector is fed to the base of transistor V618, which is balanced by transistor V619.

In the - slope position of S12 the signal on collector V619 is routed via diode V622 to the base of transistor V630 and the inverse signal on collector V618 is inhibited by the switched +12V supply which blocks diode V621.

In the + slope position of S12 the signal on collector V619 is routed via diode V621 to the base of transistor V630 and the inverse signal on collector V618 is inhibited as diode V622 is now blocked.

In the AC position of S14 diodes V620 and V625 conduct and V621 and V622 are blocked.

T.V. SYNC SEPARATOR (V630, V626, V632)

The line and frame TV trigger pulses from the slope selector stage are passed via V630 to V626 to a low-pass filter for the frame pulses. The low cut-off frequency is selected in the ms position of S2, which connects capacitor C614 across the output, and triggering on TV frame pulses is possible.

In the μ s position of S2, this capacitor is disconnected and triggering on TV line pulses is now possible.

The output on the collector of V632 (testpoint M16) applies a logic signal to pin 4 of NAND gate D701.

With TV selected (D701 input 9 at logic 0) the other input (pin 5) of D701 is at logic 1 and therefore output pin 6 is the inverted logic signal.

This signal is inverted again and appears at pin 6 of D702.

TIME-BASE (V701, V702, V703, V704, V711, V712, V707, D703, D704)

HOLD-OFF CIRCUIT (V709, V713, D701/12, 13, 11)

These two functional blocks are not described separately here because they function interdependently as shown in Fig..

The time-base is built around the timing capacitors C703, which is always in circuit, and C702, which is switched into circuit via transistor V707 at the low sweep speeds by the +12V on switch S2 (ms position) via V706 and R716.

A constant current from current source V703 charges the capacitor(s) in order to produce a time-base voltage that is linear with respect to time; i.e. a linear sawtooth.

The TIME/DIV control (S6) is incorporated in the emitter circuit of the current source transistor V703.

The TIME/DIV controls, R702 (μ s range) and R708 (ms range), adjust the base of V703 in diodes V701 and V702 respectively.

The appropriate base control circuit for V703 is selected by the position of the S2 switch, which provides the +12V to either the μ s or ms position.

The time-base capacitors are charged during the time-base sweep.

During this charging time, switching transistor V704, which is controlled by the sweep-gating logic, is not conductive. This transistor, which starts to conduct at the end of the sweep, discharges the timing capacitor(s) and takes over the current from V703.

Switching transistor V704 cuts off when the time-base is ready to start again.

The sawtooth time-base voltage on the timing capacitor is picked-off by a Darlington stage (V711 and V712), and is applied to the X-deflection selector via testpoint M18.

The output signal from V712 is also applied via R721 to emitter follower V713, which feeds the hold-off capacitors, C704 and V706. Capacitor C706 is always in circuit, and capacitor C704 is switched into circuit by V709 for the sweep speeds 5 ms to 200 ms/DIV.

The sawtooth on the hold-off capacitor(s) is applied to the input of NAND gate D702/12, 13, 11. This gate is effectively a Schmitt-trigger with a hysteresis of approximately 0.8V. The output of the gate becomes logic 0 if the positive-going slope of the input-sawtooth reaches a level of 1V approximately.

The two D flip-flop D704 operate in parallel. The non-inverting output of one flip-flop (pin 5) feeds the switching transistor V704 (via testpoint M17 and R714) and the Z-amplifier.

The non-inverting output of the other flip-flop (pin 9) is used as probe adjust signal.

Integrated circuit D703 is a retriggerable monostable multivibrator controlled by the trigger pulses from the trigger comparator. When a trigger pulse is received on pin 3, output pin 8 is at logic 1 for 150 ms. This time constant is determined by V701.

The trigger pulses are also routed to the clock inputs (pin 3 and pin 11) of the D704 flip-flops.

Free-run mode (without trigger pulses)

If no trigger pulses are available at retriggerable monostable input D703-3, then output pin 8 is low and a preset command is given to the D704 flip-flops (pins 1 and 13).

The D-flip-flops now function as inverters and the Clear inputs (pins 4 and 10) receive a pulse from the hold-off circuit after the time-base sweep, which is inverted to give outputs on pins 5 and 9.

The output pulse on D704-5 causes the switching transistor V704 to conduct at the end of the time-base sweep and during the hold-off period the time-base capacitors C702 and C703 are discharged.

In this way, the time-base capacitors are alternately discharged and then charged; i.e. the time-base is free-running.

X via A mode

When X via A is selected, the +12V that is switched to pin k of S6 performs four functions:

- via diode V609 it inhibits the trigger source input to V611
- via diode V551 a logic 1 is applied to input pin 6 of gate D551, which causes a logic 0 on input 13 of flip-flop D553. This results in channel B being switched through for Y deflection purposes and the output of channel A being blocked.
Channel A output from vertical preamplifier D301 pin 14 and 15 is routed via transistor V317 to the input of the amplifier stage (V721) to provide the X-deflection signal.
- the +12V applied via R737 to the base of V714 switches off this transistor.
The pulses from the internal time-base via M18 are now blocked by diodes V718 and V719.
- the +12V applied via R741 allows switching diodes V717 and V716 to conduct so that the output on M20 of the amplifier stage is routed to the final X amplifier.

X-DEFLECTION SELECTOR (V714, V716, V717, V718, V719)

The selection of the X via A mode has previously been described.

When the internal time-base mode is selected, V714 conducts because of the bias current applied to its base via R738 and R737. The positive voltage on the collector of V714 causes switching diodes V718, V719 to conduct, which allows the time-base output on testpoint M18 to be applied to testpoint M19 at the input of the X-amplifier. In this mode, switching diodes V716 and V717 are blocked by the negative potential applied via R738 and R741.

FINAL X AMPLIFIER (V723, V724, V726, V727, V729, V731, V733, V734, V737)

The output signal from the X deflection selector is applied to the base of V726 in the series feedback stage, which consists of V726 balanced by V723.

The base circuit of V723 incorporates the horizontal position control (X-POS) R4. Transistor V724 is the constant current source for this series feedback stage. In the x5 magnifier position of S3, resistor R762 shunts the emitter resistors R759, R761 to give a 5 times increase of horizontal gain.

The collectors of V723 and V726 are coupled to the output stage.

This output stage consists of the shunt feedback stage V731, V729 and current source V727 that feed the X-plate via testpoint M22 and R766, balanced by an identical stage comprising V733, V734 and V737.

Two transistors are employed in each of the shunt feedback stages so that the maximum current and voltage limits of the individual transistors are not exceeded, and to reduce stray capacitances.

Resistors R766 and R778 connecting the outputs to the X-plates of the c.r.t. are inserted to increase stability.

2.2.3. CRT Display Section

Z AMPLIFIER (V571, V573)

The input to the Z amplifier is via R573 to the base of transistor V573 and receives signals from:

- The sweep-gating logic (testpoint M17) in order to blank the display during the time-base hold-off period.
- The channel multivibrator in order to blank the display in the chopped mode during the switching from one channel to the other.

The Z amplifier consists of a shunt feedback stage coupled to the Wehnelt cylinder via C811. Diode V806 and resistor R818 provide d.c. restoration.

HIGH VOLTAGE CONVERTER (T801, V801, D801)

A sine wave converter formed by T801 and V801 converts the plus and minus 12V d.c. into 750V a.c. with a frequency of about 30 kHz.

This voltage is applied to a voltage doubler (C804, V802, V803, C806). The output of the voltage doubler is applied to the network R811 and C807, to smooth the 30 kHz ripple.

The negative voltage to preset the CRT is obtained from V804, R813 and R814.

To stabilize the 1500V cathode tension it is fed back via divider R801 and R802 to the positive input of op-amp D801. To the negative input the reference voltage, obtained from divider R806 and R807 is applied. The output voltage of D801-6 controls via R804 the converter.

The FOCUS control R6 is effectively part of a potential divider chain R819, R821 and R822.

TRACE ROTATION (V837, V838)

The emitter followers V807 and V808 and preset potentiometer R828 determine the sense and strength of the current in the trace rotation coil.

Only one emitter follower conducts at any given time, depending on the position of R828.

2.2.4. Power Supply

The mains voltage is applied via double-pole switch S7 to the primary winding of transformer T901, protected by a non-replaceable thermal fuse F901.

Provision is made to wire the primary for a nominal mains voltage of 110V, 220V or 240V.

Two full-wave bridge rectifiers V902 and V907 across the secondary winding of T901 provide the d.c. voltages for the +12V, -12V, +100V and -100V supplies respectively.

Diodes V903, V901 provide half-wave rectification for the +18V supply, and diodes V904, V905 provide full-wave rectification for the +5V supply.

The low-voltage supplies are regulated by four integrated circuit series stabilisers D901, D902, D903, D904 and smoothed by electrolytic capacitors C901 ... C912.

The RC filters for the individual power supply circuits are shown in Fig.

3. DISMANTLING THE INSTRUMENT

3.1. Precautions

This section provides the dismantling procedures required for the removal of components during repair and routine maintenance operation.

During dismantling procedures a careful note of all leads disconnected must be made to ensure correct reconnection to the appropriate terminal during assembly.

Always ensure that the mains supply is disconnected before removing any of the instrument cover plates. Damage may result if the instrument is switched on when a circuit-board has been removed or if a circuit-board is removed within one minute of switching-off the instrument.

Note: All screws which have to be remounted directly in the housing-parts must be fixed with a torque of maximum 1 Nm (10 kg cm).

3.2. Removing the top-cover

To adjust the instrument it is necessary to remove the top-cover.

- Remove the two carrying-handle mounting screws (fig. 1.)
- Bend the handle outwards and remove it (fig. 1.)
- Remove the two cabinet mounting-screws (fig. 1.)
- Press the two buttons at the rear side until the click.
The top-cover will lift now about 2mm (fig. 2.)
- Now lift vertically the top-cover out of the front- and rear-cover (fig. 3.)

Note: Take care of the handle mounting disks.

3.2.1. Remounting the top-cover

- Place the top-cover between the front- and rear-cover
- Take care that the side snaps of the top- and bottom-cover fix together
- Press the upper rear side firmly down until the click (fig. 2.)
- Remount cabinet mounting-screws and the handle.

3.3. Removing the power-supply-unit complete with rear-cover and CRT.

To remove the supply-unit the proceedings described in chapter 3.2.1. should be executed.

- Unlock the "POWER-ON"; "FOCUS" and "INTENS" extension spindles at the power-supply side (fig. 4.)
- Remove the plugs (fig. 4.)
- Bend the bottom-cover outwards at the rear-side and simultaneously press the rear-cover upwards (see arrows in fig. 4.)
- After the click the rear-cover complete with CRT can be removed.

Note: Take care of the two CRT clamping devices and the graticule.

3.3.1. Remounting the power-supply-unit with CRT

- Place the instrument as shown in fig. 5.
- Place the graticule so that the CRT clamping devices will fit in the slots of the graticule (fig. 5.)
- Place the rear-cover complete with CRT on the bottom-cover
- The rear-cover should be positioned so that by pressing the bottom-cover firmly (at the spots as indicated in fig. 2) it will snap together with the rear-cover.
- Unlock the clamping ring of the CRT and shift the CRT to the front as far as possible and fix it again (fig. 5.)
- Place the CRT clamping devices and press them in the indicated direction until the CRT is well fixed (fig. 5.)

3.4. Removing the front-cover with control unit.

To remove the front-cover the proceedings described in chapters 3.2.1. and 3.3.1. should be executed.

- Pull the "POWER-ON" extension spindle through the front as far as possible
- Remove the screening (two screws fig. 5.)

Note: Do not damage the reed relays when removing the screening.

- Lift the front-cover complete with control pcb out of the connector of the bottom pcb and bottom-cover (fig. 6.)

To remount the front-cover proceed in reverse sequence.

3.5. Replacing the CRT

To replace the CRT the proceedings described in chapters 3.2.1. and 3.3.1. should be executed.

- Place the rear-cover as shown in fig. 7.
- Unsolder the two wires of the trace rotation coil at the supply pcb
- Unlock the clamping ring (fig. 7.)
- Pull out the CRT complete with screening
- Pull-off the connector

To remount the CRT proceed as follows:

- The clamping ring should be first mounted on the rear-cover
- Place the screening on the CRT
- Place the filling-ring (not in all instruments) on the neck of the CRT
- Fit the connector on the CRT
- Place the CRT in the rear-cover, shift the screening between the clamping ring and the washer and fix the clamping ring (fig. 7.)
- To adjust the CRT mechanically see chapter 3.3.1.

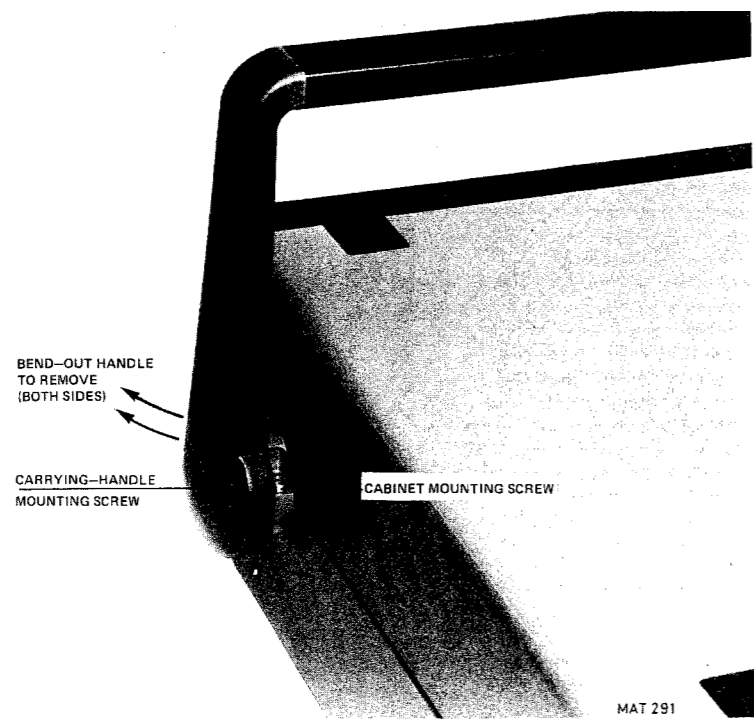

Fig. 1.

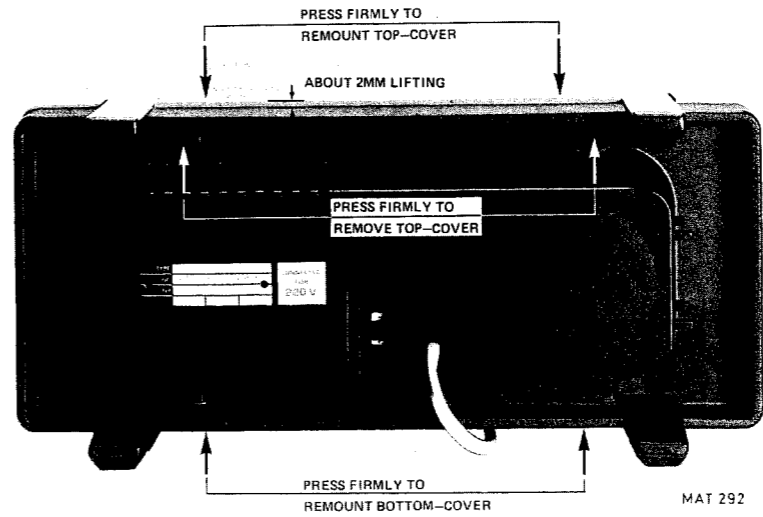

Fig. 2.

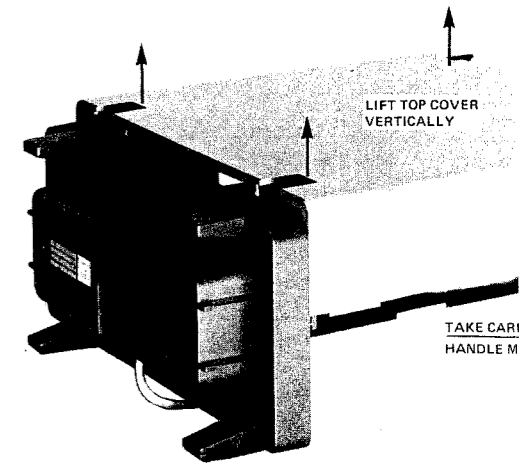

Fig. 3.

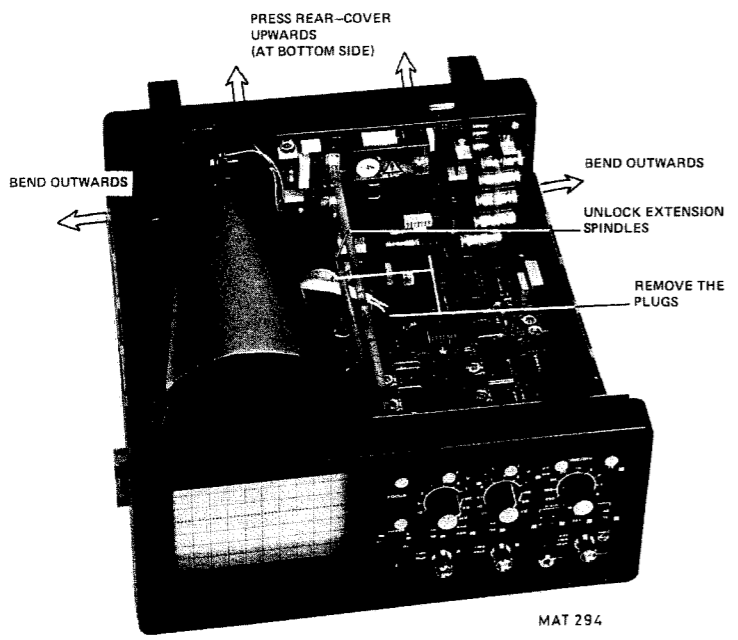

Fig. 4.

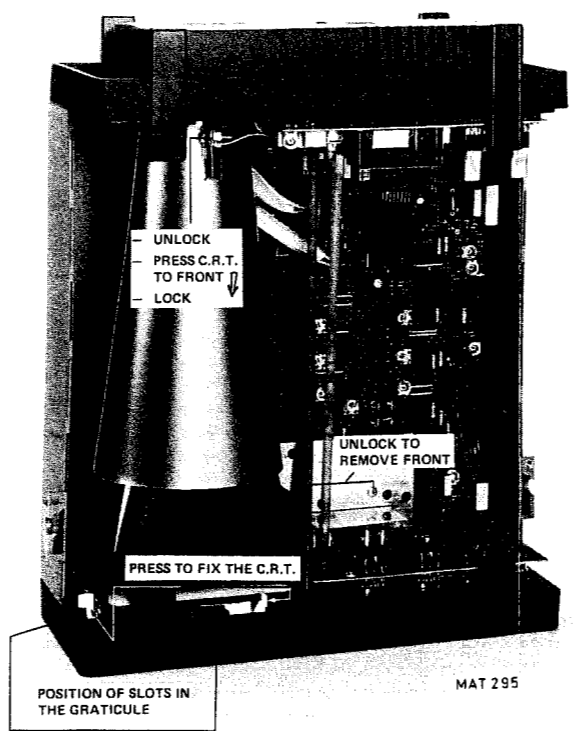

Fig. 5.

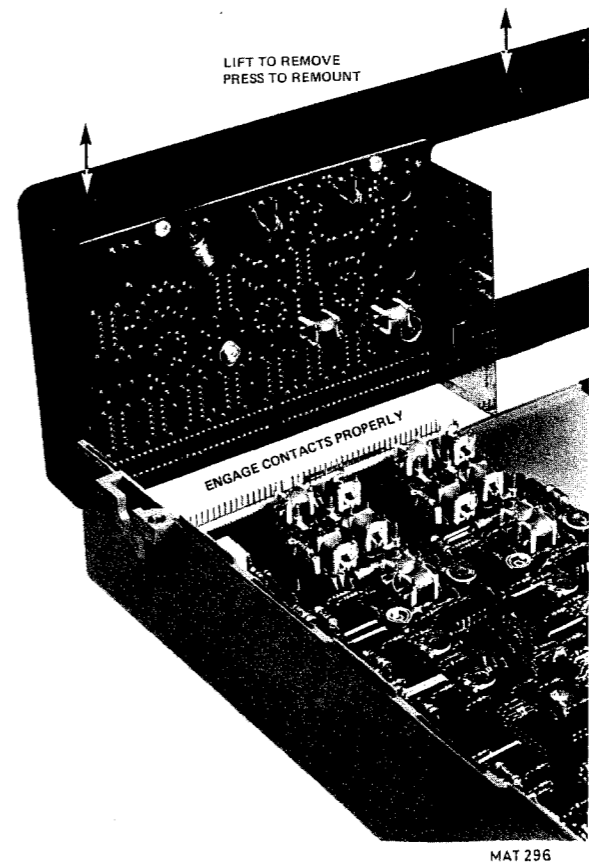

Fig. 6.

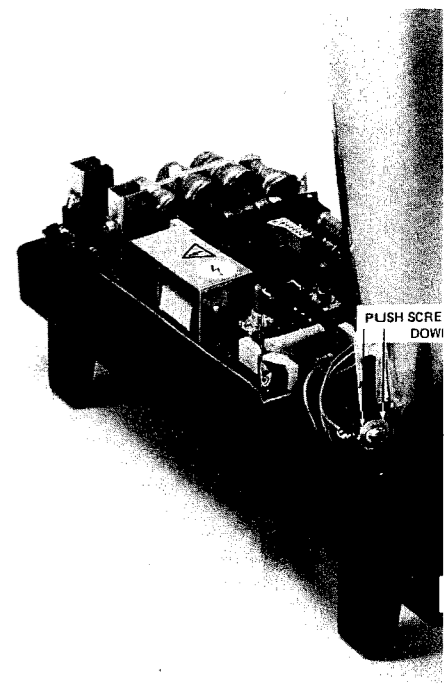

Fig. 7.

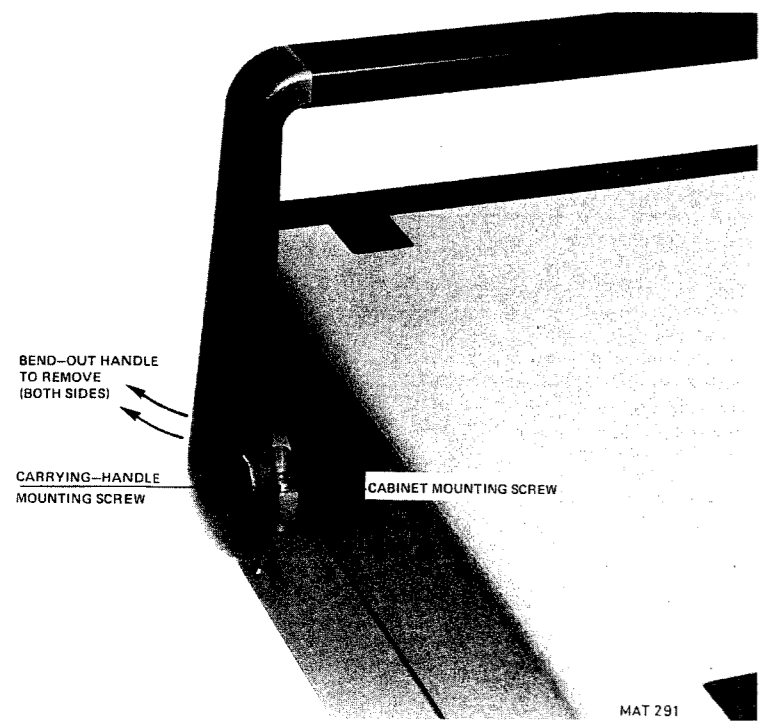

Fig. 1.

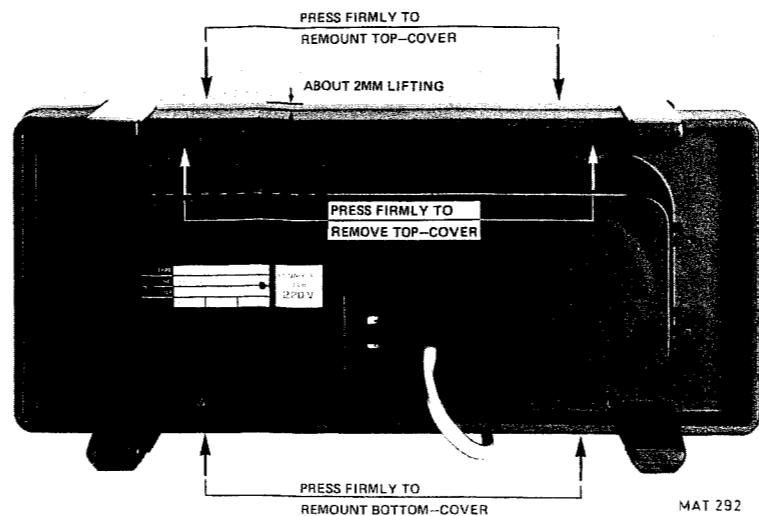

Fig. 2.

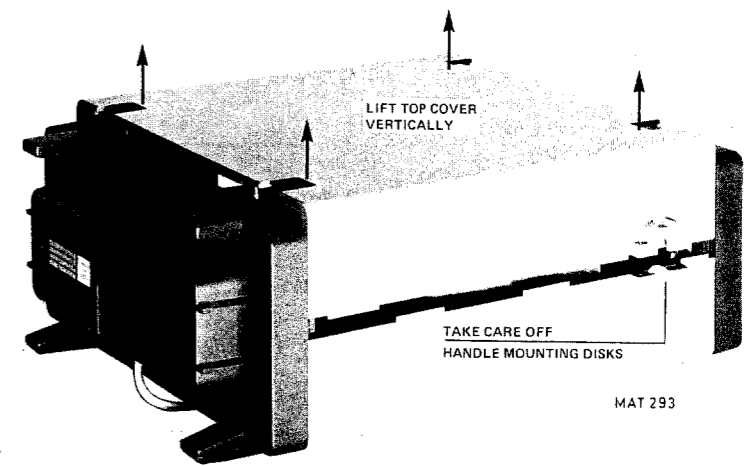

Fig. 3.

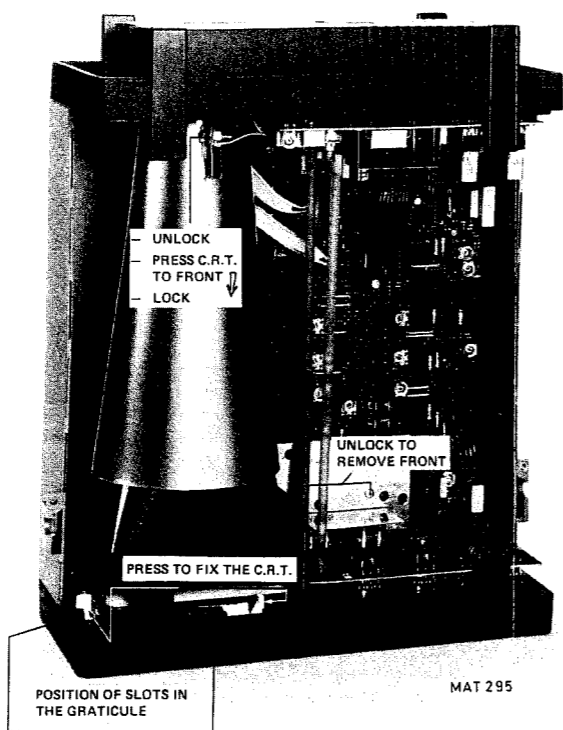
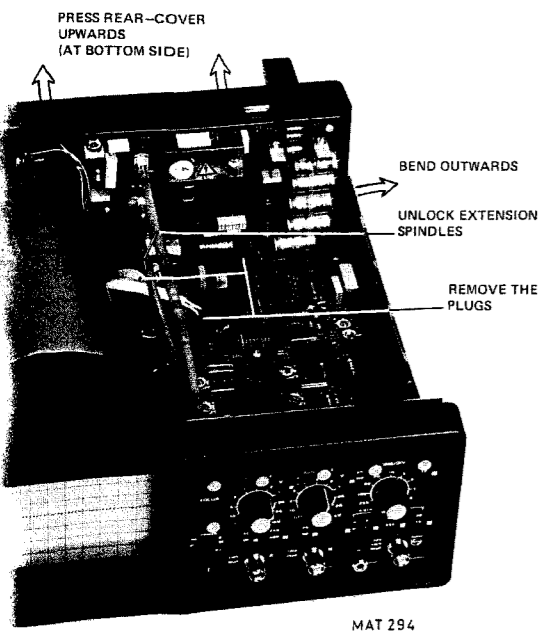

Fig. 5.

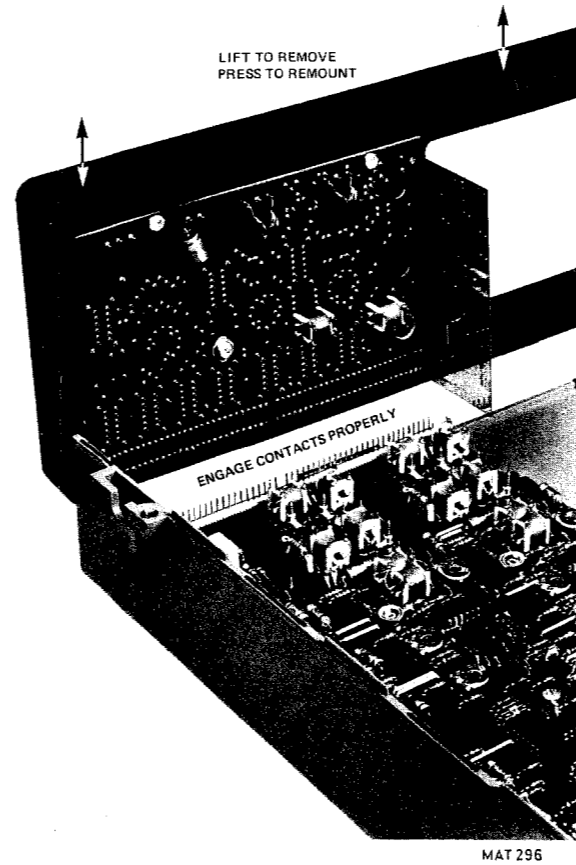

Fig. 6.

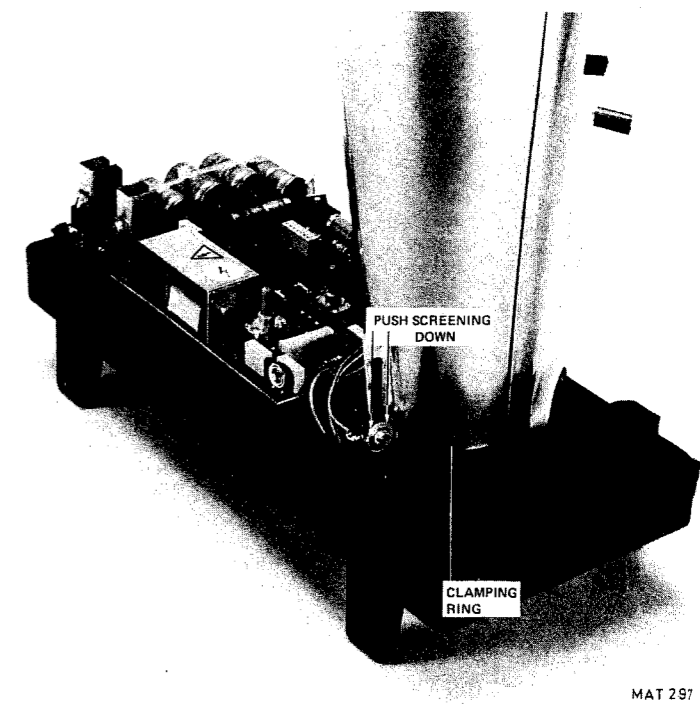

Fig. 7.

4. CHECKING AND ADJUSTING

4.1. General

Before any check or adjustment, the instrument must attain its normal operation temperature. Under average conditions this will be approximately 15 minutes after switching on.

Do not readjust any part of the instrument before having checked if the instrument meets the specifications stated in chapter 1.

If the instrument is adjusted at an ambient temperature of 23°C the tolerances given in adjusting instructions assure a correct adjustment within specification in the operating temperature range of $+5^{\circ}\text{C} \dots +40^{\circ}\text{C}$.

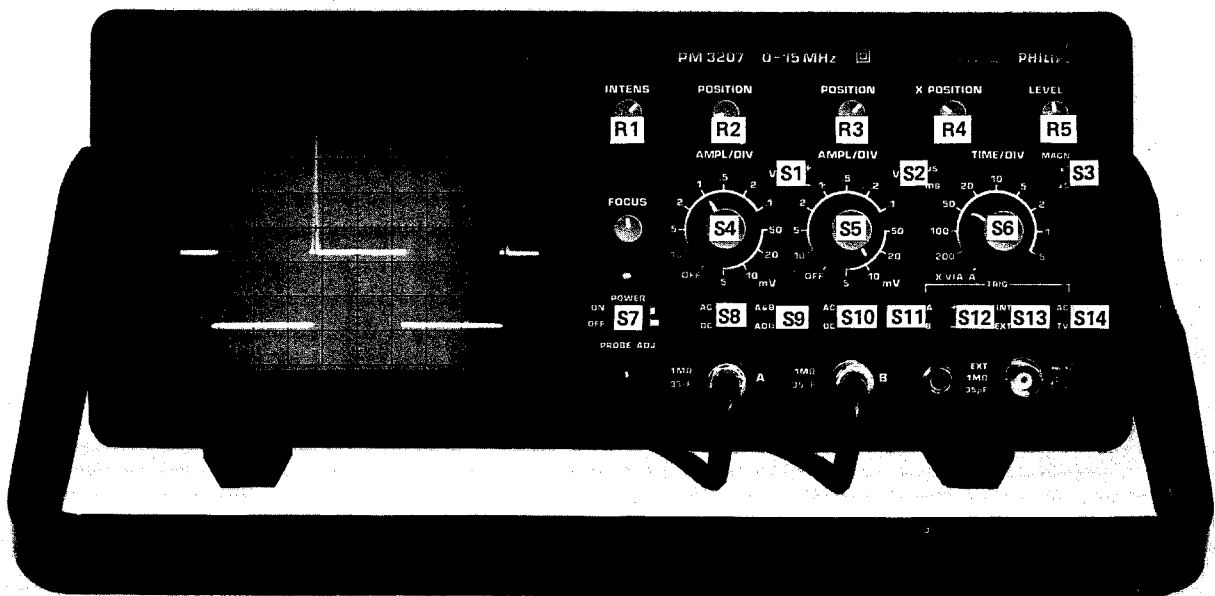

MAT 300

4.2. TABLE OF ADJUSTINGS

No.	Adjustments	Preparations		Voltages to apply to X2 (channel A) and X3 (channel B)	Adjusting element		Adjusting data	
		Controls	Description		Position	Number		Location
1.	Intensity	S4	AMPL/DIV-A	50 mV/DIV	-	R814	Supply unit	DC voltage across R823 1,25V (the current through R823 is 125 μ A then).
		S5	AMPL/DIV-B	OFF				
		S6	TIME/DIV	X via A				
		R1	INTENS	Clockwise				
		R2	POSITION-A	Adjust spot to centre of screen				
		R4	POSITION-X					
R6	FOCUS	Clockwise						
2.	Focus	as point 1.		INTENS MIDRANGE	-	R6	FOCUS	Minimum spot size
3.	Trace rotation	S2	μ s/ms	ms	-	R828	Supply unit (from DQ 1001 onwards to reach via a hole in rear panel)	Trace in parallel with horizontal graticule line
		S3	X1/X5	X1				
		S6	TIME/DIV	.5				
		R2	POSITION-A	Adjust trace to centre of screen				
R4	POSITION-X							
4.	DC bal X1 channel A (for channel B in brackets)	S1	+/- -B	+	-	R318 (R418)	A6 (B6)	Trace jump \leq $\frac{1}{2}$ div.
		S8 (S10)	AC/DC	DC				
		X2 (X3)	BNC channel A (B)	Shortcircuited				
		S4 (S5)	AMPL/DIV	20 mV = 50 mV alternately				
5.	DC bal X10 channel A (for channel B in brackets)	as point 4.		10 mV = 20 mV alternately	-	R326 (R426)	B5/6 (D5/6)	Trace jump \leq $\frac{1}{2}$ div.
6.	+/- channel B	S4	AMPL/DIV-A	OFF	-	R433	D4	Trace jump \leq $\frac{1}{2}$ div.
		S5	AMPL/DIV-B	50 mV				
		S1	+/- -B	+ = - alternately				
7.	Gain X1 channel B (channel A in brackets) REMARK: Always first adjust channel B.	S2	μ s/ms	μ s	300 mV _{pp} -2 kHz	R509 (R367)	A3 (B4)	Amplitude: 6 divisions
		S5 (S4)	AMPL/DIV	50 mV				
		S6	TIME/DIV	200				
		S11	A/B	A (B)				
		S13	INT/EXT	INT				
		S14	AC/TV	AC				
8.	Gain X10 channel A (channel B in brackets)	as point 7.		5 mV	30 mV _{pp} -2 kHz	R339 (R439)	B5 (D5)	Amplitude: 6 divisions
9.	Square-wave response A (channel B in brackets)	S1	+/- -B	+	Position 2 kHz square-wave on X2 (X3)		C312 (C412) A7 (C7) C307 (C407) A7/8 (C7/8) C308 (C408) B8 (D8)	Top side of square-wave in parallel with graticule
		S2	μ s/ms	μ s	20 mV	120 mV		
		S3	X1/X5	X1				
		S6	TIME/DIV	200	.5 V	3 V		
		S8 (S10)	AC/DC	DC				
		S9	A&B/ADD	A&B	5 V	30 V		
		S11	A/B	A (B)				
		S12	+/-	+				
		S13	INT/EXT	INT				
		S14	AC/TV	AC				
10.	HF response channel A (channel B in brackets)	S2	μ s/ms	μ s	120 mV 1 MHz square-wave Rise time \leq 5 ns	C503	A/B2	Pulse droop \leq 3% Ringing \leq 5%
		S4 (S5)	AMPL/DIV	10 mV				
		S6	TIME/DIV	.5				
		S11	A/B	A (B)				
11.	Time coefficients ms	S2	μ s/ms	ms	Apply pulse marks of 2 ms	R708	E3	8 pulses per 8 divisions
		S3	X1/X5	X1				
		S6	TIME/DIV	2				
	Time coefficients μ s	S2	μ s/ms	μ s	Apply pulse marks of 2 μ s	R702	E3	8 pulses per 8 divisions
		S6	TIME/DIV	2				
12.	Trigger sensitivity	S2	μ s/ms	ms	Apply a sine-wave of 0,6 V 2 kHz	R626	E5	Triggering in the centre of the slope
		S4 (S5)	AMPL/DIV	1 V				
		S6	TIME/DIV	2				
		R5	LEVEL	Midrange				

4.3. Survey of measuring points

To make fault finding easy, the printed circuit board has been provided with measuring points M1 up to M24.

Apply a square wave signal of 600mV peak peak to YA (YB) input.
Set AMPL/DIV in .1 Volt position.

Measuring point	Location	Values to be measured	Remarks
M1	A5	460mV p.p superimposed on 1.5V DC approx.	Signal on ch. A.
M2	A5	1.5V DC approx.	
M3	C5	460mV p.p superimposed on 1.5V DC approx.	Signal on ch. B.
M4	C5	1.5V DC approx.	
M5	A3	260mV p.p superimposed on 16.5V DC 15V DC	ch. B OFF S9 in pos A & B ch. B OFF S9 in pos ADD
M6	A3	260mV p.p superimposed on 16.5V DC 15V DC	ch. A OFF S9 in pos A & B ch. A OFF S9 in pos ADD
M7	A2	30V p.p on $38 \div 84$ V DC depending on POSITION A.	Signal on ch. A.
M8	B1	30V p.p on $38 \div 84$ V DC depending on POSITION B.	Signal on ch. B.
M9	C3	4V DC in ADD or OFF or X via A	
M10	B3	0V in pos. ADD or B OFF 5V in pos. A OFF or X via A	
M11	B3	0V in pos. ADD or A OFF or X via A 5V in pos. B OFF	
M12	D2	Blanking pulse varying with TIME/DIV pos.	
M13	E6	1.2V p.p square wave	
M14	E4	4.5V p.p square wave	
M15	E6	1.2V p.p square wave AC/TV in TV pos.	
M16	E4	μ s/ms in μ s-position needles. In ms-position no signal	
M17	D4	No trigger signal: square wave depending on TIME/DIV position. Trigger signal: square wave depending on TIME/DIV position and trigger signal.	
M18	D2	Sweep voltage (saw tooth) -1V upto +4.2V.	
M19	D1	Saw tooth (in X via 2.5V p.p square wave)	

Measuring point Location Values to be measured

M20	D2	2.5V p.p square wave
M21	E1	Position control voltage - 1.5V DC up to + 4.5V DC
M22/M23	C1	Saw tooth 100V p.p (in X via A position - 60V up to + 40V
M24	C2	32V p.p square wave superimposed on 35V DC approx.

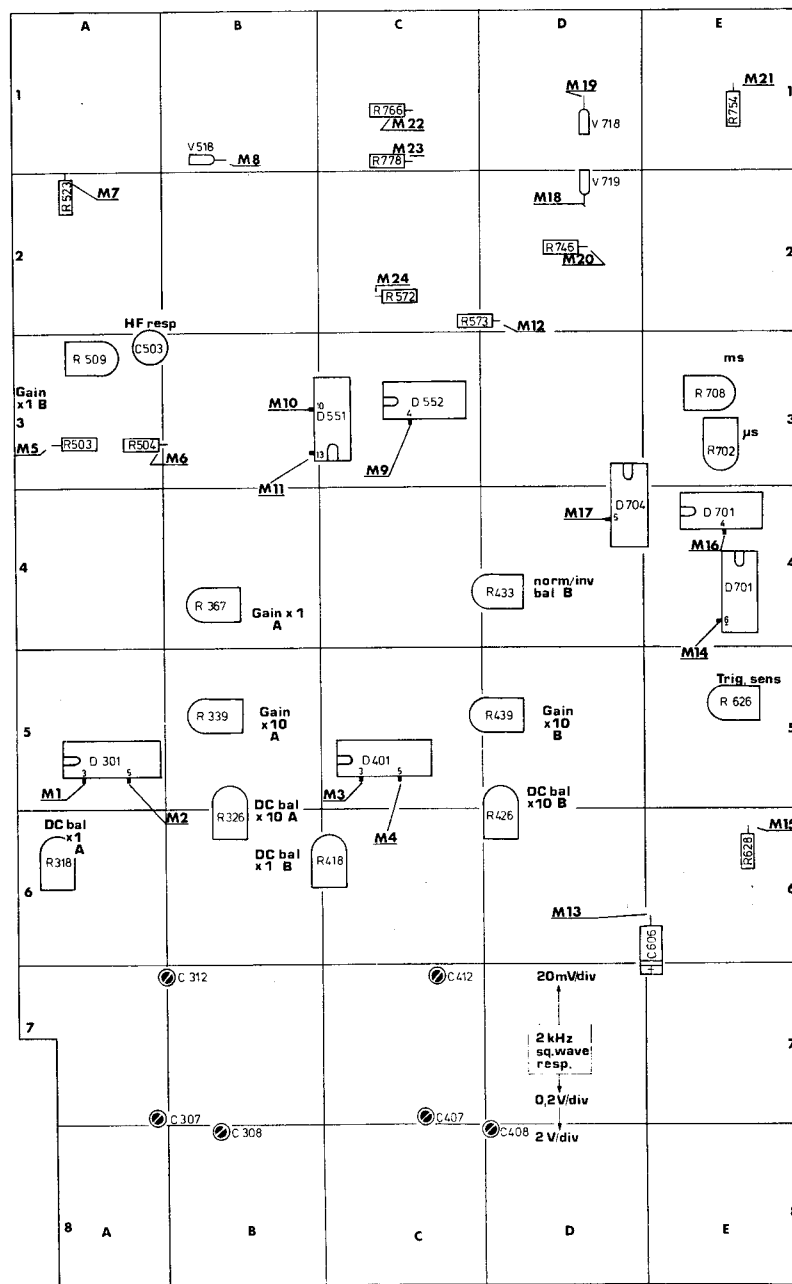

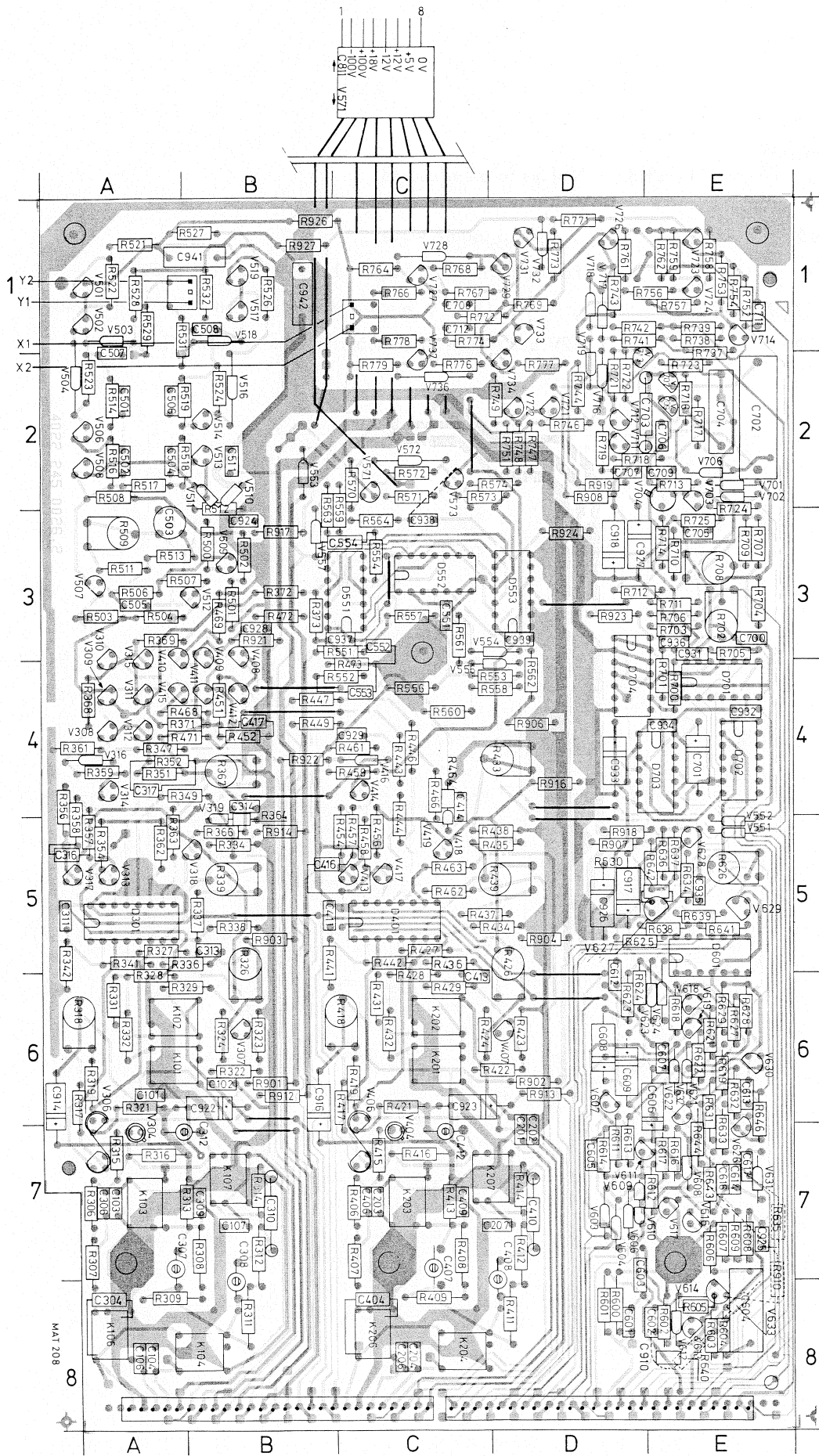

Fig. 8. Printed Circuit Board with tracks

4.4. COMPONENT LOCATION LIST

Item	Location	Item	Location	Item	Location	Item	Location	Item	Location	Item	Location	Item	Location	Item	Location	Item	Location	Item	Location	36
B1	Control unit	C613	E6	C938	C3	R323	B6	R435	C/D5	R557	C3	R705	E3	R801	Power supply	V316	A4	V621	E6	
C101	A6	C614	E7	C939	D3	R324	B6	R436	C5	R558	C/D4	R706	E3	R802	Power supply	V317	A5	V622	E6	
C102	B6	C616	E7			R326	B5/6	R437	C/D5	R559	C2/3	R707	E3	R803	Power supply	V318	B5	V623	E6	
C103	A7	C617	E7	C940	Control unit	R327	A5	R438	C/D5	R560	C4	R708	E3	R804	Power supply	V319	B4/5	V624	E6	
C104	A8	C700	E3	C941	A/B1	R328	A5/6	R439	C/D5	R561	C3	R709	E3	R806	Power supply	V404	C7	V625	Control unit	
C106	A8	C701	E4	C942	B1	R329	A/B6	R441	B5/6	R562	D4	R710	E3	R807	Power supply	V406	C6/7	V626	E6/7	
C107	B7	C702	E2	D301	A5	R331	A6	R442	C5	R563	B2/3	R711	E3	R808	Power supply	V407	D6	V627	E5	
C201	D6/7	C703	D/E2	D401	C5	R332	A6	R443	C4	R564	C3	R712	D/E3	R809	Power supply	V408	B3/4	V628	E5	
C202	D6/7	C704	E2	D551	B/C3	R334	B5	R444	C4/5	R570	C2	R713	E2	R811	Power supply	V409	B3/4	V629	E5	
C203	C7	C705	E3	D552	C3	R336	A/B5	R446	C4	R571	C2	R714	E3	R812	Power supply	V410	A/B 3/4	V630	E6	
C204	C8	C706	E2	D553	D3	R337	B5	R447	B4	R572	C2	R716	E2	R813	Power supply	V411	B4	V631	E7	
C206	C8	C707	D2	D601	E5	R338	B5	R448	Control unit	R573	C/D2	R717	E2	R814	Power supply	V412	B4	V632	E6	
C207	C/D7	C708	C1	D701	E4	R339	B5	R449	B4	R574	C/D2	R718	D/E2	R816	Power supply	V413	C5	V633	E8	
C301	Control unit	C709	E2	D702	E4	R341	A5	R449	B4	R600	D8	R719	D2	R817	Power supply	V414	C4	V701	E2	
C304	A8	C711	E1	D703	D/E4	R342	A5/6	R451	B4	R601	D8	R721	D2	R818	Power supply	V415	A/B4	V702	E2	
C306	A7	C712	C1	D704	D/E 3/4	R347	A4	R452	B4	R602	E8	R722	D2	R819	Power supply	V416	C4	V703	E2	
C307	A7	C801	Power supply	D801	Power supply	R348	Control unit	R454	C5	R603	E8	R723	E2	R820	Power supply	V417	C5	V704	E2	
C308	B7/8	C802	Power supply	D901	Power supply	R456	C5	R604	E8	R724	E2/3	R821	Power supply	V418	C5	V706	E2	V707	E2	
C309	B7	C804	Power supply	D902	Power supply	R349	A/B4	R605	E8	R725	E3	R822	Power supply	V419	C4/5	V709	E2			
C310	B7	C805	Power supply	D903	Power supply	R351	A4	R457	C5	R606	E7	R726	Control unit	R823	Power supply	V501	A1	V711	D2	
C311	A5	C806	Power supply	D904	Power supply	R352	A/B4	R458	C5	R607	E7	R727	Control unit	R828	Power supply	V502	A1	V712	D2	
C312	A/B7	C807	Power supply	K101	A/B6	R354	A4	R459	C4	R608	E7	R728	Control unit	R901	B6	V503	A1	V713	D/E2	
C313	B5	C809	Power supply	K102	A/B6	R356	A4/5	R461	C4	R609	E7	R729	Control unit	R902	D6	V504	A2	V714	E1	
C314	B4	C811	Power supply	K103	A7	R357	A4/5	R462	C5	R611	D7	R731	Control unit	R903	B5	V506	A2	V716	D2	
C316	A5	C812	Power supply	K104	A/B8	R358	A4/5	R463	C5	R612	E7	R732	Control unit	R904	D5	V507	A3	V717	D1	
C317	A4	C901	Power supply	K105	Control unit	R359	A4	R464	C4	R613	D7	R733	Control unit	R906	D4	V508	A2	V718	D1	
C401	Control unit	C902	Power supply	K106	A8	R361	A4	R466	C4	R614	D7	R734	Control unit	R907	D5	V509	B3	V719	D2	
C404	C8	C903	Power supply	K107	B7	R362	A5	R468	A/B4	R616	E7	R736	Control unit	R908	D2	V510	B2	V721	D2	
C406	C7	C904	Power supply	K201	C6	R363	A5	R469	B3	R617	E7	R737	E2	R909	Power supply	V511	B2	V722	D2	
C407	C7	C906	Power supply	K202	C6	R364	B4/5	R471	A/B4	R618	E6	R738	E1	R910	E7/8	V512	B3	V723	E1	
C408	D7/8	C907	Power supply	K203	C7	R366	B5	R472	B3	R619	E6	R739	E1	R911	Power supply	V513	B2	V724	E1	
C409	C7	C908	Power supply	K204	C8	R367	B4	R473	C4	R621	E6	R741	D/E1	R912	B6	V514	B2	V726	D1	
C410	D7	C909	Power supply	K205	Control unit	R368	A4	R500	B3	R622	E6	R742	D/E1	R913	D6	V516	B2	V727	C1	
C411	B5	C910	E8	K206	C8	R369	A3	R501	B3	R623	D6	R743	D1	R914	B5	V517	B1	V728	C1	
C412	C7	C911	Power supply	K207	C/D7	R371	A/B4	R502	B3	R624	D6	R744	D2	R916	D4	V518	B1	V729	D1	
C413	C6	C912	Power supply	R1	Power supply	R372	B3	R503	A3	R625	D/E5	R746	D2	R917	B3	V519	B1	V731	D1	
C414	C4/5	C913	Power supply	R2	Control unit	R373	B3	R504	A3	R626	E5	R747	D2	R918	D5	V520	B2	V732	D1	
C416	B/C5	C914	A6/7	R3	Control unit	R401	Control unit	R506	A3	R627	E6	R748	D2	R919	D2	V521	B3	V733	D1	
C417	B4	C915	Power supply	R4	Control unit	R402	Control unit	R507	A/B3	R628	E6	R749	D2	R921	B3	V522	E5	V734	D2	
C501	A2	C916	B6/7	R5	Control unit	R406	C7	R508	A2	R629	E6	R751	D2	R922	B4	V523	B2	V736	C2	
C502	A2	C917	D5	R6	Power supply	R407	C7	R509	A1	R630	E5	R752	E1	R923	D3	V524	B1	V737	C2	
C503	A1	C918	D3	R101	Control unit	R408	C7	R511	A3	R631	E6/7	R753	E1	R924	D3	V525	B2	V801	Power supply	
C504	A2	C919	Control unit	R102	Control unit	R409	C8	R512	B2/3	R632	E6	R754	E1	R926	B1	V526	B2	V802	Power supply	
C505	A3	C920	Control unit	R201	Control unit	R411	D8	R513	A3	R633	E6/7	R756	D/E1	R927	B1	V527	C2	V803	Power supply	
C506	A2	C921	Power supply	R202	Control unit	R412	D7	R514	A2	R634	E5	R757	E1	R928	Control unit	V601	Control unit	V804	Power supply	
C507	A1/2	C922	B6	R301	Control unit	R413	C7	R516	A2	R635	E7	R758	E1	R931	Control unit	V602	Control unit	V806	Power supply	
C508	B1	C923	C/D6	R302	Control unit	R414	D7	R517	A2	R636	E5	R759	E1	R931	Control unit	V603	D7	V807	Power supply	
C511	B2	C924	B3	R415	C7	R416	C7	R518	B2	R637	E5	R761	D1	R931	Control unit	V604	D7	V808	Power supply	
C551	C3	C925	E7	R417	C6	R417	C6	R521	A1	R638	E5	R762	E1	R931	Control unit	V605	D7	V901	Power supply	
C552	C3	C925	E7	R306	A7	R418	B/C6	R522	A1	R639	E5	R764	C1	R931	Control unit	V606	D7	V902	Power supply	
C553	C4	C926	D5	R307	A7	R419	C6	R523	A2	R640	E8	R766	C1	R931	Control unit	V607	D6	V903	Power supply	
C554	B/C3	C927	D/E3	R308	B7	R421	C6	R524	B2	R641	E5	R767	C1	R931	Control unit	V608	E7			
C601	D8	C928	B3	R309	A8	R422	C/D6	R526	B1	R642	E5	R768	C1	R931	Control unit	V609	D7			
C602	E8	C929	C4	R311	B8	R423	D6	R527	B1	R643	E7	R769	D1	R931	Control unit	V610	D7			
C603	D7/8	C931	E3	R312	B7	R424	C6	R528	A1	R644	E7	R771	D1	R931	Control unit	V611	D/E7			
C604	E8	C932	E4	R313	A/B7	R426	D5/6	R529	A1	R646	E6/7	R772	C/D1	R931	Control unit	V612	E8			
C605	D7	C933	D4	R314	B7	R427	C5	R531	A/B1	R647	Control unit	R773	D1	R931	Control unit	V613	E8			
C606	E6/7	C934	E4	R315	A7	R428	C6	R532	B1	R648	Control unit	R774	C1	R931	Control unit	V614	E8			
C607	E6	C935	E5	R316	A7	R429	C6	R551	B/C3	R700	E4	R776	C2	R931	Control unit	V615	E7			
C608	D6	C936	E3	R317	A6	R431	C6	R552	B/C4	R701	E4	R777	D2	R931	Control unit	V616	E7			
C609	D6	C937	B/C3	R318	A6	R432	C6	R553	C/D4	R702	E3	R778	C1	R931	Control unit	V617	E7			
C612	D5/6			R319	A6	R433	C/D4	R554	C3	R703	E3	R779	C2	R931	Control unit	V618	E6			
				R321	A6	R434	C/D5	R556	C4	R704	E3			R931	Control unit	V619	E6			
				R322	B6									R931	Control unit	V620	Control unit			

5. PARTS LISTS AND DIAGRAMS (subject to alternation without notice)

Mechanical parts

Item	Qty	Ordering number	Description
1	1	5322 462 54162	CRT screening
2	1	5322 401 14278	Clamping ring
3	4	5322 462 44399	Foot
4	2	5322 535 94925	Extension spindle
5	2	5322 414 34091	Controlknob dia 10
6	2	5322 414 74015	Cover with line
7	1	5322 450 74078	Screen graticule
8	2	5322 462 44398	CRT clamping device
9	1	5322 466 85808	Attenuator screening
10	1	5322 414 14011	Push button 10x6mm
11	1	5322 535 94926	Extension spindle
12	3	5322 526 44214	Arret device/switch
13	2	5322 498 54089	Handle bracket
14	1	5322 498 54088	Handle grip
15	2	5322 466 85809	Handle-mount plate
16	2	5322 535 94924	Handle-mounting pin
17	2	5322 522 34808	Handle-mounting disc
18	2	5322 502 14159	Screw 3.9x13 black
19	2	5322 447 94544	Housing bottom + top
20	1	5322 447 94545	Front-panel
21	1	5322 447 94543	Rear-panel

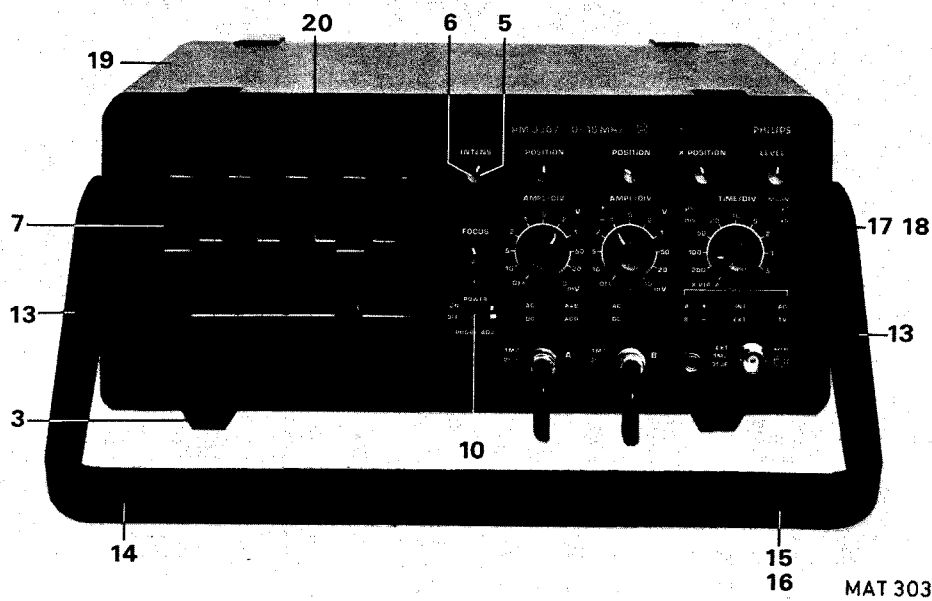

MAT 303

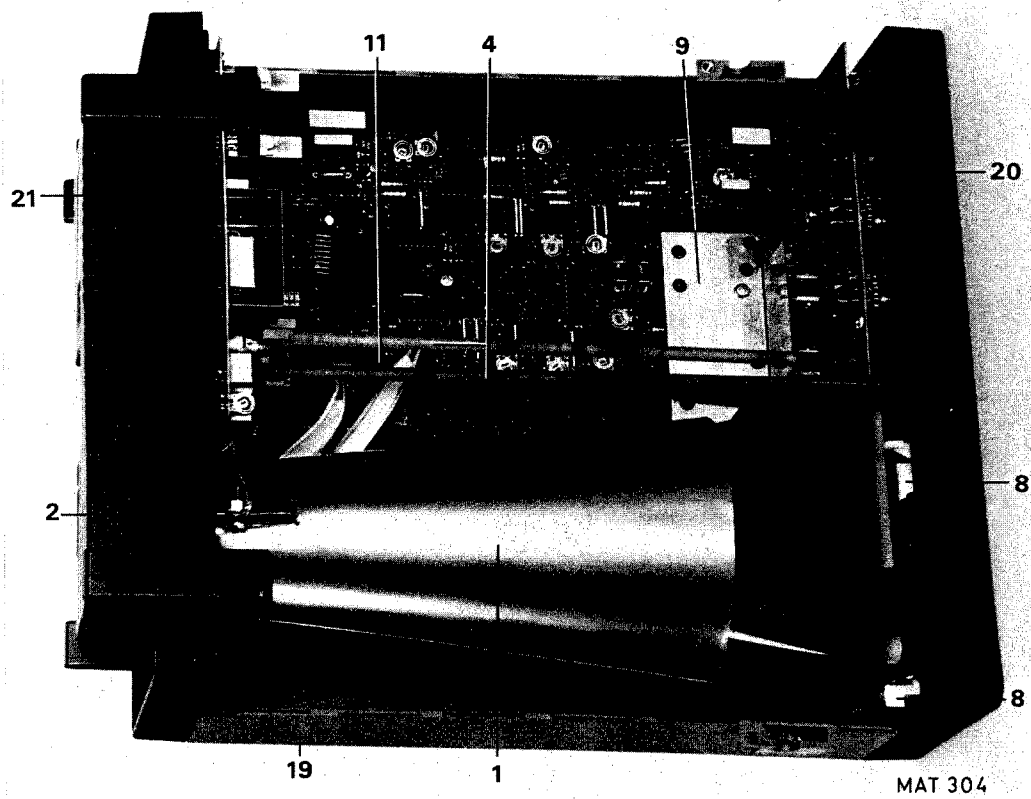

MAT 304

ITEM	ORDERING NUMBER	FARAD	TOL (%)	VOLTS	REMARKS
CAPACITORS					
C 101	4822 122 30043	10NF	-20+80	40	CERAMIC PLATE
C 102	4822 122 30043	10NF	-20+80	40	CERAMIC PLATE
C 103	4822 122 30043	10NF	-20+80	40	CERAMIC PLATE
C 104	4822 122 30043	10NF	-20+80	40	CERAMIC PLATE
C 106	4822 122 30043	10NF	-20+80	40	CERAMIC PLATE
C 107	4822 122 30043	10NF	-20+80	40	CERAMIC PLATE
C 201	4822 122 30043	10NF	-20+80	40	CERAMIC PLATE
C 202	4822 122 30043	10NF	-20+80	40	CERAMIC PLATE
C 203	4822 122 30043	10NF	-20+80	40	CERAMIC PLATE
C 204	4822 122 30043	10NF	-20+80	40	CERAMIC PLATE
C 206	4822 122 30043	10NF	-20+80	40	CERAMIC PLATE
C 207	4822 122 30043	10NF	-20+80	40	CERAMIC PLATE
C 301	4822 121 40488	22NF	10%	400	POLYESTER FOIL
C 304	4822 122 31192	6,8PF	0,25PF	500	CERAMIC PLATE
C 306	4822 122 31203	39PF	2	500	CERAMIC PLATE
C 307	5322 125 54027	5,5PF		400	TRIMMER
C 308	5322 125 54027	5,5PF		400	TRIMMER
C 309	4822 122 31067	33PF	2	100	CERAMIC PLATE
C 310	5322 121 54055	511PF	1%	250	POLYSTYRENE FOIL
C 311	4822 122 30043	10NF	-20+80	40	CERAMIC PLATE
C 312	5322 125 54027	5,5PF		400	TRIMMER
C 313	4822 122 30045	27PF	2	100	CERAMIC PLATE
C 314	4822 122 30043	10NF	-20+80	40	CERAMIC PLATE
C 316	4822 122 31054	10PF	2	100	CERAMIC PLATE
C 317	4822 122 30043	10NF	-20+80	40	CERAMIC PLATE
C 401	4822 121 40488	22NF	10%	400	POLYESTER FOIL
C 404	4822 122 31189	4,7PF	0,25PF	500	CERAMIC PLATE
C 406	4822 122 31203	39PF	2	500	CERAMIC PLATE
C 407	5322 125 54027	5,5PF		400	TRIMMER
C 408	5322 125 54027	5,5PF		400	TRIMMER
C 409	4822 122 31067	33PF	2	100	CERAMIC PLATE
C 410	5322 121 54055	511PF	1%	250	POLYSTYRENE FOIL
C 411	4822 122 30043	10NF	-20+80	40	CERAMIC PLATE
C 412	5322 125 54027	5,5PF		400	TRIMMER
C 413	4822 122 30045	27PF	2	100	CERAMIC PLATE
C 414	4822 122 30043	10NF	-20+80	40	CERAMIC PLATE
C 416	4822 122 31054	10PF	2	100	CERAMIC PLATE
C 417	4822 122 30043	10NF	-20+80	40	CERAMIC PLATE
C 501	4822 122 30105	1,5PF	0,25PF	100	CERAMIC PLATE
C 502	4822 122 30105	1,5PF	0,25PF	100	CERAMIC PLATE
C 503	4822 125 50045	22PF		250	TRIMMER
C 504	4822 122 30105	1,5PF	0,25PF	100	CERAMIC PLATE
C 505	4822 122 31054	10PF	2	100	CERAMIC PLATE
C 506	4822 122 30105	1,5PF	0,25PF	100	CERAMIC PLATE
C 507	5322 122 34041	10NF	-20+50	100	CERAMIC PLATE
C 508	5322 122 34041	10NF	-20+50	100	CERAMIC PLATE
C 511	4822 122 30043	10NF	-20+80	40	CERAMIC PLATE
C 551	4822 122 31164	1,8NF	10	100	CERAMIC PLATE
C 552	4822 122 30043	10NF	-20+80	40	CERAMIC PLATE
C 553	4822 122 30043	10NF	-20+80	40	CERAMIC PLATE
C 554	4822 122 30043	10NF	-20+80	40	CERAMIC PLATE
C 601	4822 122 31202	33PF	2	500	CERAMIC PLATE
C 602	4822 122 31219	150PF	2	500	CERAMIC PLATE
C 603	4322 121 40232	220PF	10%	100	POLYESTER FOIL
C 604	5322 121 40197	1μ F	10%	100	POLYESTER FOIL
C 605	4822 122 31081	100PF	2	100	CERAMIC PLATE
C 606	4822 124 20687	15UF	-10+50	16	ELECTROLYTIC
C 607	4822 122 31177	470PF	10	100	CERAMIC PLATE
C 608	4822 124 20726	4,7UF	-10+50	63	ELECTROLYTIC
C 609	4822 124 20726	4,7UF	-10+50	63	ELECTROLYTIC
C 612	4822 122 30043	10NF	-20+80	40	CERAMIC PLATE
C 613	4822 122 30103	22NF	-20+80	40	CERAMIC PLATE
C 614	4822 122 30128	4,7NF	10	100	CERAMIC PLATE
C 616	4822 122 30098	3,9NF	10	100	CERAMIC PLATE
C 617	4822 122 30128	4,7NF	10	100	CERAMIC PLATE
C 700	4822 122 30128	4,7NF	10	100	CERAMIC PLATE
C 701	4822 124 20476	22UF	-10+50	25	ELECTROLYTIC
C 702	5322 121 44246	330NF	10%	100	POLYESTER FOIL

ITEM	ORDERING NUMBER	FARAD	TOL (%)	VOLTS	REMARKS
C 703	4822 121 50415	2,2NF	1%	63	POLYSTYRENE FOIL
C 704	4822 121 40257	330NF	10%	100	POLYESTER FOIL
C 705	4822 122 30043	10NF	-20+80	40	CERAMIC PLATE
C 706	4822 122 31175	1NF	10	100	CERAMIC PLATE
C 707	4822 122 31175	1NF	10	100	CERAMIC PLATE
C 708	4822 122 31213	0,68PF	0,25PF	500	CERAMIC PLATE
C 709	4822 122 31085	150PF	2	100	CERAMIC PLATE
C 711	4822 122 30043	10NF	-20+80	40	CERAMIC PLATE
C 712	4822 122 31213	0,68PF	0,25PF	500	CERAMIC PLATE
C 801	4822 122 30114	2,2NF	10	100	CERAMIC PLATE
C 802	5322 121 40323	100NF	10%	100	POLYESTER FOIL
C 804	4822 121 40192	10NF	10%	1000	POLYESTER FOIL
C 805	5322 121 44138	47NF	10%	250	POLYESTER FOIL
C 806	4822 121 40363	10NF	10%	1600	POLYESTER FOIL
C 807	4822 121 40363	10NF	10%	1600	POLYESTER FOIL
C 808	5322 121 40323	100NF	10%	100	POLYESTER FOIL
C 809	5322 121 40323	100NF	10%	100	POLYESTER FOIL
C 811	4822 121 40363	10NF	10%	1600	POLYESTER FOIL
C 812	5322 121 40323	100NF	10%	100	POLYESTER FOIL
C 901	4822 124 20697	10UF	-10+50	25	ELECTROLYTIC
C 902	4822 124 20687	15UF	-10+50	16	ELECTROLYTIC
C 903	4822 124 20687	15UF	-10+50	16	ELECTROLYTIC
C 904	4822 124 20687	15UF	-10+50	16	ELECTROLYTIC
C 906	5322 124 24221	100UF	-10+50	160	ELECTROLYTIC
C 907	5322 124 24222	47UF	-10+50	160	ELECTROLYTIC
C 908	4822 124 20794	680UF	-10+50	40	ELECTROLYTIC
C 909	4822 124 20786	1000UF	-10+50	25	ELECTROLYTIC
C 910	4822 122 30043	10NF	-20+80	40	CERAMIC PLATE
C 911	4822 124 20786	1000UF	-10+50	25	ELECTROLYTIC
C 912	4822 124 20685	680UF	-10+50	10	ELECTROLYTIC
C 913	4822 124 20776	680UF	-10+50	16	ELECTROLYTIC
C 914	4822 124 20687	15UF	-10+50	16	ELECTROLYTIC
C 915	4822 121 40239	47NF			POLYESTER FOIL
C 916	4822 124 20687	15UF	-10+50	16	ELECTROLYTIC
C 917	4822 124 20687	15UF	-10+50	16	ELECTROLYTIC
C 918	4822 124 20687	15UF	-10+50	16	ELECTROLYTIC
C 919	4822 124 20689	68UF	-10+50	16	ELECTROLYTIC
C 921	4822 124 20701	100UF	-10+50	25	ELECTROLYTIC
C 922	4822 124 20687	15UF	-10+50	16	ELECTROLYTIC
C 923	4822 124 20687	15UF	-10+50	16	ELECTROLYTIC
C 924	4822 122 30043	10NF	-20+80	40	CERAMIC PLATE
C 925	4822 122 30043	10NF	-20+80	40	CERAMIC PLATE
C 926	4822 124 20687	15UF	-10+50	16	ELECTROLYTIC
C 927	4822 124 20687	15UF	-10+50	16	ELECTROLYTIC
C 928	4822 122 30043	10NF	-20+80	40	CERAMIC PLATE
C 929	4822 122 30043	10NF	-20+80	40	CERAMIC PLATE
C 931	4822 122 30043	10NF	-20+80	40	CERAMIC PLATE
C 932	4822 122 30043	10NF	-20+80	40	CERAMIC PLATE
C 933	4822 124 20687	15UF	-10+50	16	ELECTROLYTIC
C 934	4822 122 30043	10NF	-20+80	40	CERAMIC PLATE
C 935	4822 122 30043	10NF	-20+80	40	CERAMIC PLATE
C 936	4822 122 30043	10NF	-20+80	40	CERAMIC PLATE
C 937	4822 122 30043	10NF	-20+80	40	CERAMIC PLATE
C 938	4822 122 30043	10NF	-20+80	40	CERAMIC PLATE
C 939	4822 122 30043	10NF	-20+80	40	CERAMIC PLATE
C 940	4822 122 30043	10NF	-20+80	40	CERAMIC PLATE
C 941	5322 121 44137	68NF	10%	250	POLYESTER FOIL
C 942	5322 121 44137	68NF	10%	250	POLYESTER FOIL

ITEM	ORDERING NUMBER	OHM	TOL (%)	TYPE	REMARKS
RESISTORS					
R 1	5322 101 24162	220K	20	0.1W	CARBON POTM LIN
R 2	5322 101 24159	220	20	0.1W	CARBON POTM LIN
R 3	5322 101 24159	220	20	0.1W	CARBON POTM LIN
R 4	5322 101 24164	10K	20	0.1W	CARBON POTM LIN
R 5	5322 101 24164	10K	20	0.1W	CARBON POTM LIN
R 6	5322 101 24163	4,7M	20	0.1W	CARBON POTM LIN
R 101	5322 116 54629	14K	1	MR25	METAL FILM
R 102	5322 116 50636	2,74K	1	MR25	METAL FILM
R 201	5322 116 54629	14K	1	MR25	METAL FILM
R 202	5322 116 50636	2,74K	1	MR25	METAL FILM
R 301	5322 116 50876	26,1	1	MR25	METAL FILM
R 302	5322 116 54549	1K	1	MR25	METAL FILM
R 306	5322 116 55356	105K	0,5	MR25	METAL FILM
R 307	5322 116 55356	105K	0,5	MR25	METAL FILM
R 308	5322 116 55382	953K	0,5	MR30	METAL FILM
R 309	5322 116 55381	866K	0,5	MR30	METAL FILM
R 311	5322 116 55275	1M	0,5	MR30	METAL FILM
R 312	5322 116 55383	976K	0,5	MR30	METAL FILM
R 313	5322 116 55364	196K	0,5	MR25	METAL FILM
R 314	5322 116 55361	16,2K	0,5	MR25	METAL FILM
R 315	5322 116 54442	51,1	1	MR25	METAL FILM
R 316	5322 116 55378	787K	0,5	MR30	METAL FILM
R 317	5322 116 50572	12,1K	1	MR25	METAL FILM
R 318	5322 100 10112	1K	20	0,5W	TRIMMING POTM
R 319	5322 116 50572	12,1K	1	MR25	METAL FILM
R 321	5322 116 54442	51,1	1	MR25	METAL FILM
R 322	5322 116 54606	7,15K	1	MR25	METAL FILM
R 323	5322 116 50509	4,87K	1	MR25	METAL FILM
R 324	5322 116 54532	649	1	MR25	METAL FILM
R 326	4822 100 10052	100K	20	0.05W	TRIMMING POTM
R 327	5322 116 54696	100K	1	MR25	METAL FILM
R 328	5322 116 55365	205	0,5	MR25	METAL FILM
R 329	5322 116 55365	205	0,5	MR25	METAL FILM
R 331	5322 116 55368	383	0,5	MR25	METAL FILM
R 332	5322 116 55375	82,5	0,5	MR25	METAL FILM
R 334	5322 116 50586	1,54K	1	MR25	METAL FILM
R 336	5322 116 54192	5,11	1	MR25	METAL FILM
R 337	5322 116 54466	90,9	1	MR25	METAL FILM
R 338	5322 116 50586	1,54K	1	MR25	METAL FILM
R 339	5322 101 14047	470	20	0,5W	TRIMMING POTM
R 341	5322 116 50556	4,42K	1	MR25	METAL FILM
R 342	5322 116 54549	1K	1	MR25	METAL FILM
R 347	5322 116 54519	402	1	MR25	METAL FILM
R 348	5322 116 54543	866	1	MR25	METAL FILM
R 349	5322 116 54519	402	1	MR25	METAL FILM
R 351	5322 116 54012	6,81K	1	MR25	METAL FILM
R 352	5322 116 54623	11K	1	MR25	METAL FILM
R 354	5322 116 54519	402	1	MR25	METAL FILM
R 356	5322 116 54519	402	1	MR25	METAL FILM
R 357	5322 116 54506	287	1	MR25	METAL FILM
R 358	5322 116 54506	287	1	MR25	METAL FILM
R 359	5322 116 54561	1,33K	1	MR25	METAL FILM
R 361	5322 116 54597	5,36K	1	MR25	METAL FILM
R 362	5322 116 54543	866	1	MR25	METAL FILM
R 363	5322 116 50664	2,05K	1	MR25	METAL FILM
R 364	5322 116 54619	10K	1	MR25	METAL FILM
R 366	5322 116 54558	8,25K	1	MR25	METAL FILM
R 367	5322 101 14008	2,2K	20	0.5W	TRIMMING POTM
R 368	5322 116 54597	5,36K	1	MR25	METAL FILM
R 369	5322 116 50572	12,1K	1	MR25	METAL FILM
R 371	5322 116 54617	9,53K	1	MR25	METAL FILM
R 372	5322 116 54635	16,9K	1	MR25	METAL FILM
R 373	5322 116 50572	12,1K	1	MR25	METAL FILM
R 401	5322 116 50876	26,1	1	MR25	METAL FILM
R 402	5322 116 54549	1K	1	MR25	METAL FILM
R 406	5322 116 55356	105K	0,5	MR25	METAL FILM
R 407	5322 116 55356	105K	0,5	MR25	METAL FILM
R 408	5322 116 55382	953K	0,5	MR30	METAL FILM

ITEM	ORDERING NUMBER	OHM	TOL (%)	TYPE	REMARKS
R 409	5322 116 55381	866K	0,5	MR30	METAL FILM
R 411	5322 116 55275	1M	0,5	MR30	METAL FILM
R 412	5322 116 55383	976K	0,5	MR30	METAL FILM
R 413	5322 116 55364	196K	0,5	MR25	METAL FILM
R 414	5322 116 55361	16,2K	0,5	MR25	METAL FILM
R 415	5322 116 54442	51,1	1	MR25	METAL FILM
R 416	5322 116 55378	787K	0,5	MR30	METAL FILM
R 417	5322 116 50572	12,1K	1	MR25	METAL FILM
R 418	5322 100 10112	1K	20	0,5W	TRIMMING POTM
R 419	5322 116 50572	12,1K	1	MR25	METAL FILM
R 421	5322 116 54442	51,1	1	MR25	METAL FILM
R 422	5322 116 54606	7,15K	1	MR25	METAL FILM
R 423	5322 116 50509	4,87K	1	MR25	METAL FILM
R 424	5322 116 54532	649	1	MR25	METAL FILM
R 425	4822 100 10052	100K	20	0,05W	TRIMMING POTM
R 427	5322 116 54696	100K	1	MR25	METAL FILM
R 428	5322 116 55365	205	0,5	MR25	METAL FILM
R 429	5322 116 55365	205	0,5	MR25	METAL FILM
R 431	5322 116 55368	383	0,5	MR25	METAL FILM
R 432	5322 116 55375	82,5	0,5	MR25	METAL FILM
R 433	5322 100 10112	1K	20	0,5W	TRIMMING POTM
R 434	5322 116 50586	1,54K	1	MR25	METAL FILM
R 435	5322 116 54561	1,33K	1	MR25	METAL FILM
R 436	5322 116 54192	5,11	1	MR25	METAL FILM
R 437	5322 116 54466	90,9	1	MR25	METAL FILM
R 438	5322 116 54519	402	1	MR25	METAL FILM
R 439	5322 101 14047	470	20	0,5W	TRIMMING POTM
R 441	5322 116 50556	4,42K	1	MR25	METAL FILM
R 442	5322 116 54549	1K	1	MR25	METAL FILM
R 443	5322 116 54442	51,1	1	MR25	METAL FILM
R 444	5322 116 54549	1K	1	MR25	METAL FILM
R 446	5322 116 54442	51,1	1	MR25	METAL FILM
R 447	5322 116 54519	402	1	MR25	METAL FILM
R 448	5322 116 54543	866	1	MR25	METAL FILM
R 449	5322 116 54519	402	1	MR25	METAL FILM
R 451	5322 116 54012	6,81K	1	MR25	METAL FILM
R 452	5322 116 54623	11K	1	MR25	METAL FILM
R 454	5322 116 54519	402	1	MR25	METAL FILM
R 456	5322 116 54519	402	1	MR25	METAL FILM
R 457	5322 116 54506	287	1	MR25	METAL FILM
R 458	5322 116 54506	287	1	MR25	METAL FILM
R 459	5322 116 54561	1,33K	1	MR25	METAL FILM
R 461	5322 116 54597	5,36K	1	MR25	METAL FILM
R 462	5322 116 54543	866	1	MR25	METAL FILM
R 463	5322 116 54543	866	1	MR25	METAL FILM
R 464	5322 116 54619	10K	1	MR25	METAL FILM
R 466	5322 116 54558	8,25K	1	MR25	METAL FILM
R 468	5322 116 54597	5,36K	1	MR25	METAL FILM
R 469	5322 116 50572	12,1K	1	MR25	METAL FILM
R 471	5322 116 54617	9,53K	1	MR25	METAL FILM
R 472	5322 116 54635	16,9K	1	MR25	METAL FILM
R 473	5322 116 50572	12,1K	1	MR25	METAL FILM
R 500	5322 116 54549	1K	1	MR25	METAL FILM
R 501	5322 116 54595	5,11K	1	MR25	METAL FILM
R 502	5322 116 54595	5,11K	1	MR25	METAL FILM
R 503	5322 116 55366	301	0,5	MR25	METAL FILM
R 504	5322 116 55366	301	0,5	MR25	METAL FILM
R 506	5322 116 50556	4,42K	1	MR25	METAL FILM
R 507	5322 116 50556	4,42K	1	MR25	METAL FILM
R 508	5322 116 54676	56,2K	1	MR25	METAL FILM
R 509	5322 101 14011	100	20	0,5W	TRIMMING POTM
R 511	5322 116 54426	121	1	MR25	METAL FILM
R 512	5322 116 54676	56,2K	1	MR25	METAL FILM
R 513	5322 116 54442	51,1	1	MR25	METAL FILM
R 514	5322 116 54011	5,62K	1	MR25	METAL FILM
R 516	5322 116 54011	5,62K	1	MR25	METAL FILM
R 517	5322 116 54549	1K	1	MR25	METAL FILM
R 518	5322 116 54011	5,62K	1	MR25	METAL FILM
R 519	5322 116 54011	5,62K	1	MR25	METAL FILM
R 521	5322 116 54011	5,62K	1	MR25	METAL FILM

ITEM	ORDERING NUMBER	OHM	TOL (%)	TYPE	REMARKS
R 522	5322 116 54011	5,62K	1	MR25	METAL FILM
R 523	5322 116 54426	121	1	MR25	METAL FILM
R 524	5322 116 54426	121	1	MR25	METAL FILM
R 526	5322 116 54011	5,62K	1	MR25	METAL FILM
R 527	5322 116 54011	5,62K	1	MR25	METAL FILM
R 528	5322 116 54696	100K	1	MR25	METAL FILM
R 529	5322 116 55365	205	0,5	MR25	METAL FILM
R 531	5322 116 55365	205	0,5	MR25	METAL FILM
R 532	5322 116 54696	100K	1	MR25	METAL FILM
R 551	5322 116 54587	3,65K	1	MR25	METAL FILM
R 552	5322 116 54587	3,65K	1	MR25	METAL FILM
R 553	5322 116 54587	3,65K	1	MR25	METAL FILM
R 554	5322 116 54549	1K	1	MR25	METAL FILM
R 556	5322 116 54549	1K	1	MR25	METAL FILM
R 557	5322 116 54549	1K	1	MR25	METAL FILM
R 558	5322 116 54587	3,65K	1	MR25	METAL FILM
R 559	5322 116 54587	3,65K	1	MR25	METAL FILM
R 560	5322 116 54549	1K	1	MR25	METAL FILM
R 561	5322 116 54606	7,15K	1	MR25	METAL FILM
R 562	5322 116 54606	7,15K	1	MR25	METAL FILM
R 563	5322 116 50515	1,78K	1	MR25	METAL FILM
R 564	5322 116 54525	511	1	MR25	METAL FILM
R 570	5322 116 54643	20,5K	1	MR25	METAL FILM
R 571	5322 116 54643	20,5K	1	MR25	METAL FILM
R 572	5322 116 54504	274	1	MR25	METAL FILM
R 573	5322 116 50664	2,05K	1	MR25	METAL FILM
R 574	5322 116 50556	4,42K	1	MR25	METAL FILM
R 600	5322 116 55376	402K	0,5	MR30	METAL FILM
R 601	5322 116 55379	845K	0,5	MR30	METAL FILM
R 602	5322 116 54743	301K	1	MR25	METAL FILM
R 603	5322 116 54011	5,62K	1	MR25	METAL FILM
R 604	5322 116 54011	5,62K	1	MR25	METAL FILM
R 605	5322 116 50876	26,1	1	MR25	METAL FILM
R 606	5322 116 54655	30,1K	1	MR25	METAL FILM
R 607	5322 116 50561	590	1	MR25	METAL FILM
R 608	5322 116 54587	3,65K	1	MR25	METAL FILM
R 609	5322 116 50561	590	1	MR25	METAL FILM
R 611	5322 116 50664	2,05K	1	MR25	METAL FILM
R 612	5322 116 54561	1,33K	1	MR25	METAL FILM
R 613	5322 116 54549	1K	1	MR25	METAL FILM
R 614	5322 116 50664	2,05K	1	MR25	METAL FILM
R 616	5322 116 54549	1K	1	MR25	METAL FILM
R 617	5322 116 54587	3,65K	1	MR25	METAL FILM
R 618	5322 116 55365	205	0,5	MR25	METAL FILM
R 619	5322 116 54619	10K	1	MR25	METAL FILM
R 621	5322 116 54549	1K	1	MR25	METAL FILM
R 622	5322 116 54549	1K	1	MR25	METAL FILM
R 623	5322 116 50672	51,1K	1	MR25	METAL FILM
R 624	5322 116 50672	51,1K	1	MR25	METAL FILM
R 625	5322 116 54426	121	1	MR25	METAL FILM
R 626	4822 100 10036	4,7K	20	0.05W	TRIMMING POTM
R 627	5322 116 50509	4,87K	1	MR25	METAL FILM
R 628	5322 116 50664	2,05K	1	MR25	METAL FILM
R 629	5322 116 54606	7,15K	1	MR25	METAL FILM
R 630	5322 116 54426	121	1	MR25	METAL FILM
R 631	5322 116 55275	1M	0,5	MR30	METAL FILM
R 632	5322 116 54619	10K	1	MR25	METAL FILM
R 633	5322 116 50579	3,16K	1	MR25	METAL FILM
R 634	5322 116 54011	5,62K	1	MR25	METAL FILM
R 635	5322 116 54619	10K	1	MR25	METAL FILM
R 636	5322 116 50515	1,78K	1	MR25	METAL FILM
R 637	5322 116 54549	1K	1	MR25	METAL FILM
R 638	5322 116 50876	26,1	1	MR25	METAL FILM
R 639	5322 116 54592	4,02K	1	MR25	METAL FILM
R 640	5322 116 54619	10K	1	MR25	METAL FILM
R 641	5322 116 50876	26,1	1	MR25	METAL FILM
R 642	5322 116 54549	1K	1	MR25	METAL FILM
R 643	5322 116 55275	1M	0,5	MR30	METAL FILM
R 644	5322 116 54725	196K	1	MR25	METAL FILM
R 646	5322 116 50664	2,05K	1	MR25	METAL FILM

ITEM	ORDERING NUMBER	OHM	TOL (%)	TYPE	REMARKS
R 647	5322 116 54606	7,15K	1	MR25	METAL FILM
R 648	5322 116 50509	4,87K	1	MR25	METAL FILM
R 700	5322 116 54549	1K	1	MR25	METAL FILM
R 701	5322 116 54595	5,11K	1	MR25	METAL FILM
R 702	4822 100 10051	22K	20	0.05W	TRIMMING POTM
R 703	5322 116 54635	16,9K	1	MR25	METAL FILM
R 704	5322 116 54643	20,5K	1	MR25	METAL FILM
R 705	5322 116 54619	10K	1	MR25	METAL FILM
R 706	5322 116 50579	3,16K	1	MR25	METAL FILM
R 707	5322 116 54635	16,9K	1	MR25	METAL FILM
R 708	4822 100 10051	22K	20	0.05W	TRIMMING POTM
R 709	5322 116 54635	16,9K	1	MR25	METAL FILM
R 710	5322 116 54619	10K	1	MR25	METAL FILM
R 711	5322 116 50579	3,16K	1	MR25	METAL FILM
R 712	5322 116 54606	7,15K	1	MR25	METAL FILM
R 713	5322 116 54442	51,1	1	MR25	METAL FILM
R 714	5322 116 54549	1K	1	MR25	METAL FILM
R 716	5322 116 54011	5,62K	1	MR25	METAL FILM
R 717	5322 116 54623	11K	1	MR25	METAL FILM
R 718	5322 116 54442	51,1	1	MR25	METAL FILM
R 719	5322 116 54655	30,1K	1	MR25	METAL FILM
R 721	5322 116 54511	316	1	MR25	METAL FILM
R 722	5322 116 50664	2,05K	1	MR25	METAL FILM
R 723	5322 116 50672	51,1K	1	MR25	METAL FILM
R 724	5322 116 54504	274	1	MR25	METAL FILM
R 725	5322 116 50572	12,1K	1	MR25	METAL FILM
R 726	5322 116 55377	768K	0,5	MR30	METAL FILM
R 727	5322 116 55371	383K	0,5	MR25	METAL FILM
R 728	5322 116 55363	191K	0,5	MR25	METAL FILM
R 729	5322 116 55373	76,8K	0,5	MR25	METAL FILM
R 731	5322 116 55369	38,3K	0,5	MR25	METAL FILM
R 732	5322 116 55362	18,7K	0,5	MR25	METAL FILM
R 733	5322 116 55372	7,32K	0,5	MR25	METAL FILM
R 734	5322 116 55367	3,48K	0,5	MR25	METAL FILM
R 736	5322 116 55359	1,62K	0,5	MR25	METAL FILM
R 737	5322 116 50672	51,1K	1	MR25	METAL FILM
R 738	5322 116 54643	20,5K	1	MR25	METAL FILM
R 739	5322 116 54696	100K	1	MR25	METAL FILM
R 741	5322 116 54595	5,11K	1	MR25	METAL FILM
R 742	5322 116 54595	5,11K	1	MR25	METAL FILM
R 743	5322 116 54643	20,5K	1	MR25	METAL FILM
R 744	5322 116 54561	1,33K	1	MR25	METAL FILM
R 746	5322 116 54592	4,02K	1	MR25	METAL FILM
R 747	5322 116 50515	1,78K	1	MR25	METAL FILM
R 748	5322 116 54515	348	1	MR25	METAL FILM
R 749	5322 116 54619	10K	1	MR25	METAL FILM
R 751	5322 116 54617	9,53K	1	MR25	METAL FILM
R 752	5322 116 50484	4,64K	1	MR25	METAL FILM
R 753	5322 116 50675	2,26K	1	MR25	METAL FILM
R 754	5322 116 50414	2,87K	1	MR25	METAL FILM
R 756	5322 116 54536	750	1	MR25	METAL FILM
R 757	5322 116 50664	2,05K	1	MR25	METAL FILM
R 758	5322 116 54619	10K	1	MR25	METAL FILM
R 759	5322 116 50664	2,05K	1	MR25	METAL FILM
R 761	5322 116 50664	2,05K	1	MR25	METAL FILM
R 762	5322 116 54545	909	1	MR25	METAL FILM
R 764	5322 116 55374	82,5K	0,5	MR25	METAL FILM
R 766	5322 116 54525	511	1	MR25	METAL FILM
R 767	5322 116 55374	82,5K	0,5	MR25	METAL FILM
R 768	5322 116 54515	348	1	MR25	METAL FILM
R 769	5322 116 54635	16,9K	1	MR25	METAL FILM
R 771	5322 116 50579	3,16K	1	MR25	METAL FILM
R 772	5322 116 50579	3,16K	1	MR25	METAL FILM
R 773	5322 116 50579	3,16K	1	MR25	METAL FILM
R 774	5322 116 55374	82,5K	0,5	MR25	METAL FILM
R 776	5322 116 54515	348	1	MR25	METAL FILM
R 777	5322 116 54696	100K	1	MR25	METAL FILM
R 778	5322 116 54525	511	1	MR25	METAL FILM
R 779	5322 116 55374	82,5K	0,5	MR25	METAL FILM
R 801	4822 110 42214	10M	1	VR37	CARBON

ITEM	ORDERING NUMBER	OHM	TOL (%)	TYPE	REMARKS
R 802	5322 116 55374	82,5K	0,5	MR25	METAL FILM
R 803	5322 116 55275	1M	0,5	MR30	METAL FILM
R 804	5322 116 50451	21,5K	1	MR25	METAL FILM
R 806	5322 116 55358	11,5K	0,5	MR25	METAL FILM
R 807	5322 116 55357	10,7K	0,5	MR25	METAL FILM
R 808	5322 116 54549	1K	1	MR25	METAL FILM
R 809	5322 116 54619	10K	1	MR25	METAL FILM
R 811	5322 116 50672	51,1K	1	MR25	METAL FILM
R 812	5322 116 54706	127K	1	MR25	METAL FILM
R 813	5322 116 54619	10K	1	MR25	METAL FILM
R 814	4822 100 10022	220K	20	0.05W	TRIMMING POTM
R 816	5322 116 54595	5,11K	1	MR25	METAL FILM
R 817	5322 116 54549	1K	1	MR25	METAL FILM
R 818	4822 110 42223	22M	5	VR37	CARBON
R 819	5322 116 55382	953K	0,5	MR30	METAL FILM
R 820	5322 116 54525	511	1	MR25	METAL FILM
R 821	5322 116 55275	1M	0,5	MR30	METAL FILM
R 822	5322 116 64027	7,5M	5	VR37	METAL OXIDE
R 823	5322 116 54619	10K	1	MR25	METAL FILM
R 828	4822 100 10072	100K	20	0.05W	TRIMMING POTM
R 901	5322 116 50876	26,1	1	MR25	METAL FILM
R 902	5322 116 50876	26,1	1	MR25	METAL FILM
R 903	5322 116 54192	5,11	1	MR25	METAL FILM
R 904	5322 116 54192	5,11	1	MR25	METAL FILM
R 906	5322 116 54192	5,11	1	MR25	METAL FILM
R 907	5322 116 54192	5,11	1	MR25	METAL FILM
R 908	5322 116 54192	5,11	1	MR25	METAL FILM
R 909	5322 116 54192	5,11	1	MR25	METAL FILM
R 910	5322 116 50876	26,1	1	MR25	METAL FILM
R 911	5322 116 54192	5,11	1	MR25	METAL FILM
R 912	5322 116 50876	26,1	1	MR25	METAL FILM
R 913	5322 116 50876	26,1	1	MR25	METAL FILM
R 914	5322 116 54192	5,11	1	MR25	METAL FILM
R 916	5322 116 54192	5,11	1	MR25	METAL FILM
R 917	5322 116 54192	5,11	1	MR25	METAL FILM
R 918	5322 116 54192	5,11	1	MR25	METAL FILM
R 919	5322 116 54192	5,11	1	MR25	METAL FILM
R 921	5322 116 54192	5,11	1	MR25	METAL FILM
R 922	5322 116 54192	5,11	1	MR25	METAL FILM
R 923	5322 116 54192	5,11	1	MR25	METAL FILM
R 924	5322 116 54192	5,11	1	MR25	METAL FILM
R 926	5322 116 54192	5,11	1	MR25	METAL FILM
R 927	5322 116 54192	5,11	1	MR25	METAL FILM
R 928	5322 116 54532	649	1	MR25	METAL FILM
R 931	5322 116 54192	5,11	1	MR25	METAL FILM

ITEM	ORDERING NUMBER	TYPE/DESCRIPTION
SEMI CONDUCTORS		
V 1	5322 131 24055	D14-250GH/A
V 101	4822 130 30613	BAW62
V 102	4822 130 30613	BAW62
V 103	4822 130 30613	BAW62
V 104	4822 130 30613	BAW62
V 106	4822 130 30613	BAW62
V 107	4822 130 30613	BAW62
V 108	4822 130 30613	BAW62
V 109	4822 130 30613	BAW62
V 111	4822 130 30613	BAW62
V 112	4822 130 30613	BAW62
V 113	4822 130 30613	BAW62
V 114	4822 130 30613	BAW62
V 116	4822 130 30613	BAW62
V 117	4822 130 44197	BC558B
V 118	4822 130 30613	BAW62
V 119	4822 130 30613	BAW62
V 120	4822 130 30613	BAW62
V 121	4822 130 30613	BAW62
V 201	4822 130 30613	BAW62
V 202	4822 130 30613	BAW62
V 203	4822 130 30613	BAW62
V 204	4822 130 30613	BAW62
V 206	4822 130 30613	BAW62
V 207	4822 130 30613	BAW62
V 208	4822 130 30613	BAW62
V 209	4822 130 30613	BAW62
V 211	4822 130 30613	BAW62
V 212	4822 130 30613	BAW62
V 213	4822 130 30613	BAW62
V 214	4822 130 30613	BAW62
V 216	4822 130 30613	BAW62
V 217	4822 130 44197	BC558B
V 218	4822 130 30613	BAW62
V 219	4822 130 30613	BAW62
V 220	4822 130 30613	BAW62
V 221	4822 130 30613	BAW62
V 304	5322 130 34037	BAV45
V 306	5322 130 44643	ON561
V 307	4822 130 44196	BC548C
V 308	4822 130 44196	BC548C
V 309	4822 130 44196	BC548C
V 310	4822 130 44196	BC548C
V 311	4822 130 44196	BC548C
V 312	4822 130 44196	BC548C
V 313	4822 130 44197	BC558B
V 314	4822 130 44197	BC558B
V 315	4822 130 44196	BC548C
V 316	4822 130 34174	BZX79-C4V7
V 317	4822 130 44197	BC558B
V 318	4822 130 44196	BC548C
V 404	5322 130 34037	BAV45
V 406	5322 130 44643	ON561
V 407	4822 130 44196	BC548C
V 408	4822 130 44196	BC548C
V 409	4822 130 44196	BC548C
V 410	4822 130 44196	BC548C
V 411	4822 130 44196	BC548C
V 412	4822 130 44196	BC548C
V 413	4822 130 44197	BC558B
V 414	4822 130 44197	BC558B
V 415	4822 130 44196	BC548C
V 416	4822 130 34174	BZX79-C4V7
V 417	4822 130 44197	BC558B
V 418	4822 130 44196	BC548C
V 501	4822 130 44154	BF199
V 502	4822 130 44154	BF199
V 503	4822 130 34258	BZX79-C56

ITEM	ORDERING NUMBER	TYPE/DESCRIPTION
V 504	4822 130 34047	BZX75-C1V4
V 506	4822 130 44154	BF199
V 507	4822 130 44154	BF199
V 508	4822 130 44154	BF199
V 509	4822 130 44196	BC548C
V 510	5322 130 34297	BZX79-C10
V 511	5322 130 34297	BZX79-C10
V 512	4822 130 44154	BF199
V 513	4822 130 44154	BF199
V 514	4822 130 44154	BF199
V 516	4822 130 34047	BZX75-C1V4
V 517	4822 130 44154	BF199
V 518	4822 130 34258	BZX79-C56
V 519	4822 130 44154	BF199
V 551	4822 130 30613	BAW62
V 552	4822 130 30613	BAW62
V 553	4822 130 30613	BAW62
V 554	4822 130 30613	BAW62
V 556	4822 130 30613	BAW62
V 557	4822 130 30613	BAW62
V 571	4822 130 41084	BF422 PH
V 572	4822 130 34047	BZX75-C1V4
V 573	4822 130 41084	BF422 PH
V 601	4822 130 30613	BAW62
V 602	4822 130 30613	BAW62
V 603	4822 130 30613	BAW62
V 604	4822 130 30613	BAW62
V 606	4822 130 30613	BAW62
V 607	4822 130 44154	BF199
V 608	4822 130 34167	BZX79-C6V2
V 609	4822 130 30613	BAW62
V 610	4822 130 34173	BZX79-C5V6
V 611	4822 130 44196	BC548C
V 612	4822 130 30613	BAW62
V 613	4822 130 44197	BC558B
V 614	4822 130 44197	BC558B
V 616	4822 130 44197	BC558B
V 617	4822 130 44197	BC558B
V 618	4822 130 44196	BC548C
V 619	4822 130 44196	BC548C
V 620	4822 130 30613	BAW62
V 621	4822 130 30613	BAW62
V 622	4822 130 30613	BAW62
V 623	4822 130 30191	OA95 PH
V 624	4822 130 30191	OA95 PH
V 625	4822 130 30613	BAW62
V 626	4822 130 44196	BC548C
V 627	4822 130 44154	BF199
V 628	4822 130 44197	BC558B
V 629	4822 130 44154	BF199
V 630	4822 130 44197	BC558B
V 631	4822 130 30613	BAW62
V 632	4822 130 44197	BC558B
V 633	4822 130 30613	BAW62
V 701	4822 130 30613	BAW62
V 702	4822 130 30613	BAW62
V 703	4822 130 44197	BC558B
V 704	5322 130 40417	BSX20
V 706	4822 130 30613	BAW62
V 707	4822 130 44196	BC548C
V 709	4822 130 44196	BC548C
V 711	4822 130 44196	BC548C
V 712	4822 130 44196	BC548C
V 713	4822 130 44196	BC548C
V 714	4822 130 44197	BC558B
V 716	4822 130 30613	BAW62
V 717	4822 130 30613	BAW62
V 718	4822 130 30613	BAW62
V 719	4822 130 30613	BAW62
V 721	4822 130 44196	BC548C

ITEM	ORDERING NUMBER	TYPE/DESCRIPTION
V 722	4822 130 44196	BC548C
V 723	4822 130 41106	BF423 PH
V 724	4822 130 44197	BC558B
V 726	4822 130 41106	BF423 PH
V 727	4822 130 41084	BF422 PH
V 728	4822 130 34047	BZX75-C1V4
V 729	4822 130 41084	BF422 PH
V 731	4822 130 44196	BC548C
V 732	4822 130 34167	BZX79-C6V2
V 733	4822 130 44196	BC548C
V 734	4822 130 41084	BF422 PH
V 736	4822 130 34047	BZX75-C1V4
V 737	4822 130 41084	BF422 PH
V 801	4822 130 40855	BC337
V 802	5322 130 34594	BY409-A
V 803	5322 130 34594	BY409-A
V 804	5322 130 34122	BZX79-C39
V 806	4822 130 30613	BAW62
V 807	4822 130 44196	BC548C
V 808	4822 130 44197	BC558B
V 901	4822 130 34121	BAX18
V 902	4822 130 30414	BY164
V 903	4822 130 34121	BAX18
V 904	4822 130 34121	BAX18
V 906	4822 130 34121	BAX18
V 907	4822 130 30521	BY179

INTEGRATED CIRCUITS

D 301	5322 209 85627	OQ0017
D 401	5322 209 85627	OQ0017
D 551	5322 209 85312	N74LS02N SC
D 552	5322 209 85201	N74LS132N SC
D 553	5322 209 84165	N7474N SC
D 601	5322 209 85899	LM324N
D 701	5322 209 85201	N74LS132N SC
D 702	5322 209 84997	N74LS86N SC
D 703	5322 209 84231	N74122N SC
D 704	5322 209 84165	N7474N SC
D 801	5322 209 85254	UA741CN SC
D 901	4822 209 80404	UA7818UC FA
D 902	5322 209 85577	78M12CU SC
D 903	5322 209 85769	79M12CU SC
D 904	5322 209 85718	78M05CU

ITEM	ORDERING NUMBER	MISCELLANEOUS
K 101	5322 280 24123	REED RELAIS ASSY
K 102	5322 280 24123	REED RELAIS ASSY
K 103	5322 280 24123	REED RELAIS ASSY
K 104	5322 280 24123	REED RELAIS ASSY
K 105	5322 280 24123	REED RELAIS ASSY
K 106	5322 280 24123	REED RELAIS ASSY
K 107	5322 280 24123	REED RELAIS ASSY
K 201	5322 280 24123	REED RELAIS ASSY
K 202	5322 280 24123	REED RELAIS ASSY
K 203	5322 280 24123	REED RELAIS ASSY
K 204	5322 280 24123	REED RELAIS ASSY
K 205	5322 280 24123	REED RELAIS ASSY
K 206	5322 280 24123	REED RELAIS ASSY
K 207	5322 280 24123	REED RELAIS
S 1	5322 277 24077	SHIFT SWITCH
S 2	5322 277 24077	SHIFT SWITCH
S 3	5322 277 24077	SHIFT SWITCH
S 4	5322 273 34121	ROTARY SWITCH
S 5	5322 273 34121	ROTARY SWITCH
S 6	5322 273 34119	ROTARY SWITCH
S 7	4822 276 10529	MAINS SWITCH
S 8	5322 277 24077	SHIFT SWITCH
S 9	5322 277 24077	SHIFT SWITCH
S 10	5322 277 24077	SHIFT SWITCH
S 11	5322 277 24077	SHIFT SWITCH
S 12	5322 277 24077	SHIFT SWITCH
S 13	5322 277 24077	SHIFT SWITCH
S 14	5322 277 24077	SHIFT SWITCH
T 801	5322 146 14173	CONVERTER TRANSFORMER
T 901	5322 146 44055	MAINS TRANSFORMERS
X 2	5322 267 10004	HF-CON BNC BUS
X 3	5322 267 10004	HF-CON BNC BUS
X 4	5322 535 84346	EARTH CON.
X 5	5322 267 10004	HF-CON BNC BUS
	4822 321 10084	MAINS CABLE
	5322 325 64083	GROMMET
	UNITS COMPLETE	
	5322 455 84081	CONTROL UNIT
	5322 216 54224	POWER SUPPLY

5.1. ADAPTION OF MAINS (LINE) VOLTAGE

Before opening any part of the instrument it must be disconnected from all voltage sources.

Access to the power supply unit:

- Remove the two handle mounting screws
- Bend the handle brackets outwards and remove it
- Remove the two cabinet mounting screws which become visible now
- Press firmly the two buttons of the rear cover until the click (the top cover will lift for approx. 2mm)
- Now lift vertically the top cover out of the front and rear-cover
- The power supply board is accessible now to adapt the mains voltage
- Connections should be changed as follows:

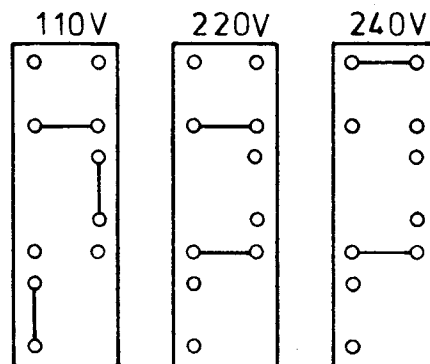

PINNING OF CONNECTOR

AMPLIFIER UNITCONTROL UNIT

n.c.	o 56 o	n.c.
n.c.	o 55 o	n.c.
R700	o 54 o	X1
R762	o 53 o	S3-12
V726	o 52 o	S3-11
V551	o 51 o	S6-k
V552	o 50 o	S5-l
D702-2	o 49 o	S12-5
V633	o 48 o	S2-9
R752	o 47 o	R4-wiper
R711	o 46 o	S2-3
R724	o 45 o	R726 ... R736
D701-2/9	o 44 o	S12-6
0V	o 43 o	0V
R601	o 42 o	X5
V617-C	o 41 o	S13-7
V619-C	o 40 o	S12-10/V625
V618-C	o 39 o	S12-12/V620
V604	o 38 o	S11-6/V602
V603	o 37 o	S13-7/V601
D601-1/2	o 36 o	R5
D601-9/8	o 35 o	R5
D601-12	o 34 o	R5-wiper
0V	o 33 o	0V
+12V	o 32 o	+12V
-12V	o 31 o	-12V
R462	o 30 o	S1-4
R463	o 29 o	S1-6
Coil K202	o 28 o	S5-d/V201/V206/V213
Coil K201	o 27 o	S5-c/V203/V209
Coil K203	o 26 o	S5-h/V204/V207
Coil K207	o 25 o	V219/V221
Coil K204	o 24 o	V208/V211/R201
Coil K206	o 23 o	V216/V217
n.c.	o 22 o	n.c.
K204/K206	o 21 o	K205/C401
R441	o 20 o	S5-b/V202
R552	o 19 o	S4-L/V120/V121
R551	o 18 o	S5-L/V220/V221
R449	o 17 o	R3
R447	o 16 o	R3
V533	o 15 o	S9-12
Coil K102	o 14 o	S4-d/V101/V106/V113
R347	o 13 o	R2
Coil K101	o 12 o	S4-c/V103/V109
R349	o 11 o	R2
+18V	o 10 o	+18V
R341	o 9 o	S4-b/V102
Coil K103	o 8 o	S4-h/V104/V107
Coil K107	o 7 o	V119/V121
Coil K104	o 6 o	V108/V111/R101
Coil K106	o 5 o	V116/V117
n.c.	o 4 o	n.c.
K104/K106	o 3 o	K105/C501
n.c.	o 2 o	n.c.
n.c.	o 1 o	n.c.

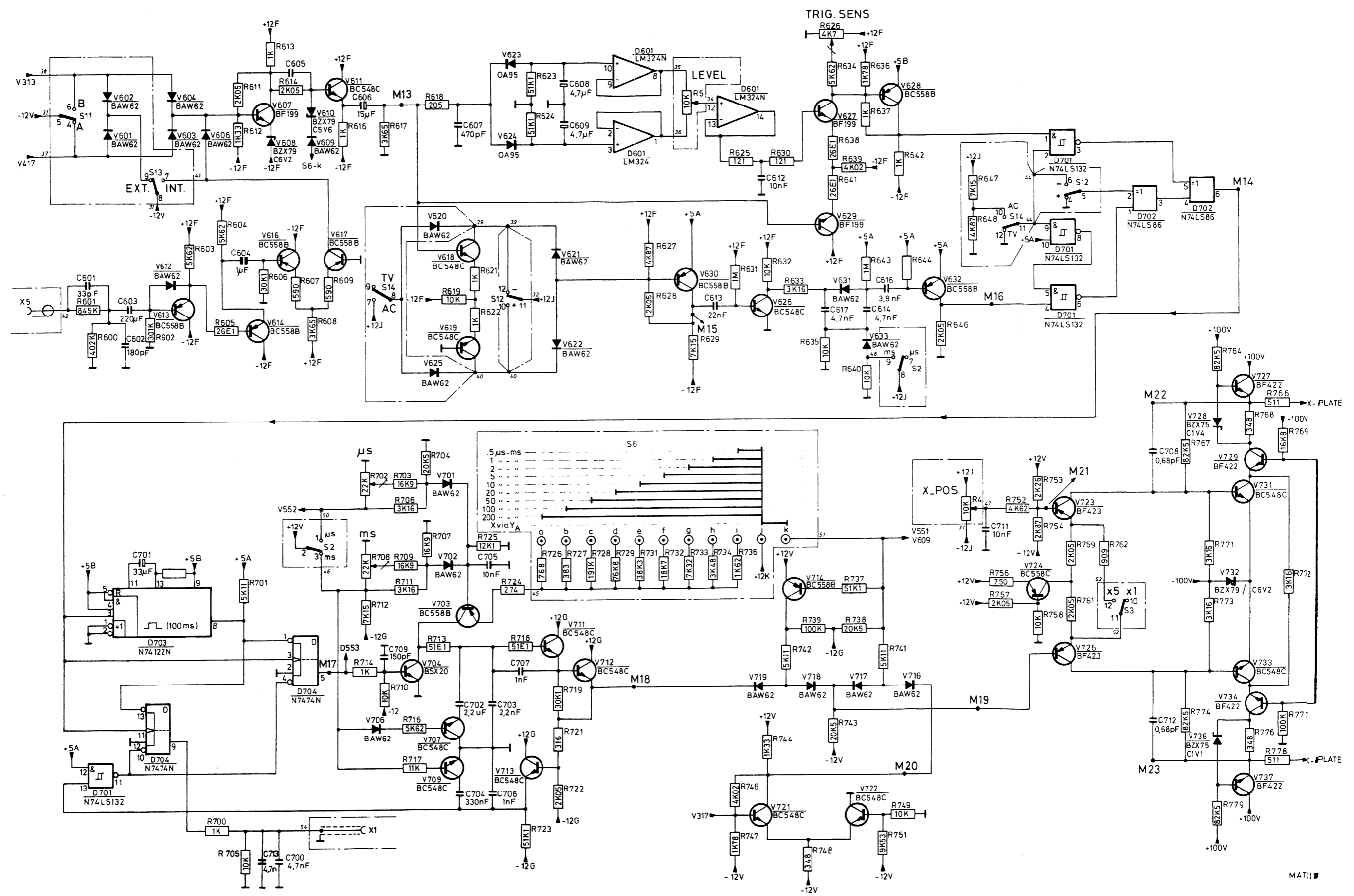

Fig. 9. Circuit diagram X-channel and Timebase

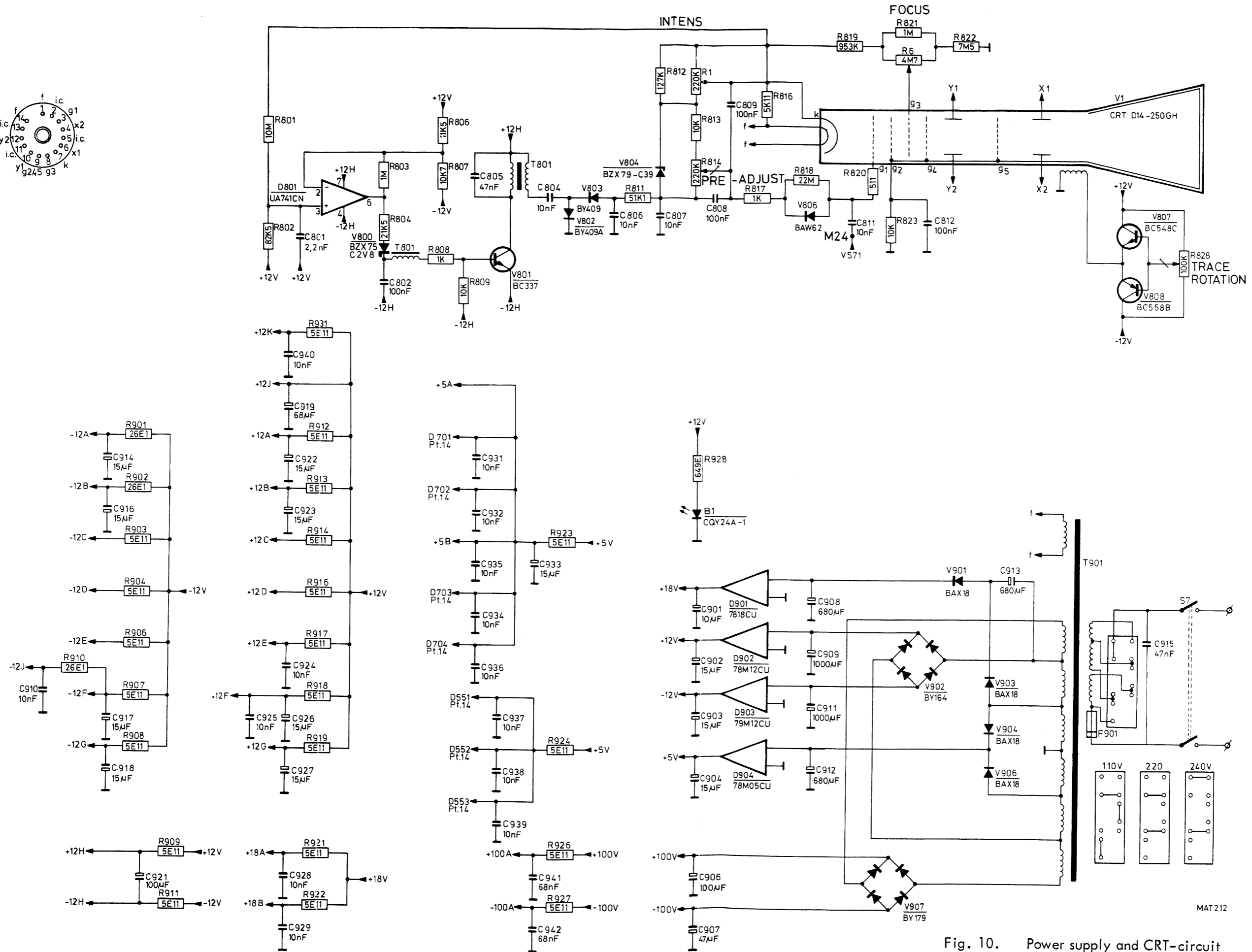
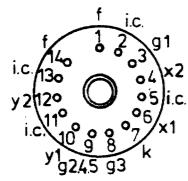

Fig. 10. Power supply and CRT-circuit

MAT 212

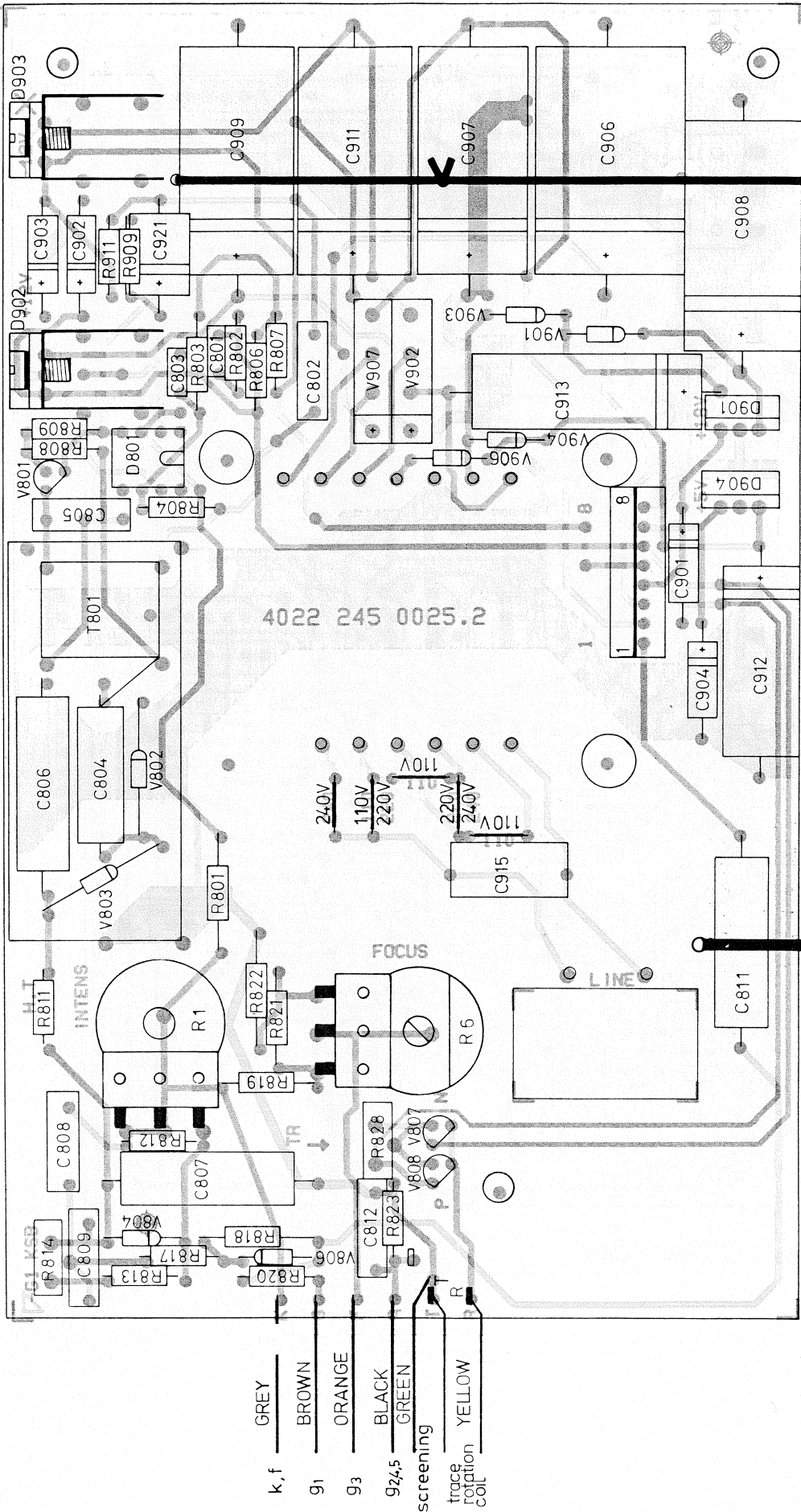

Fig. 11. P.c.b. of Power Supply

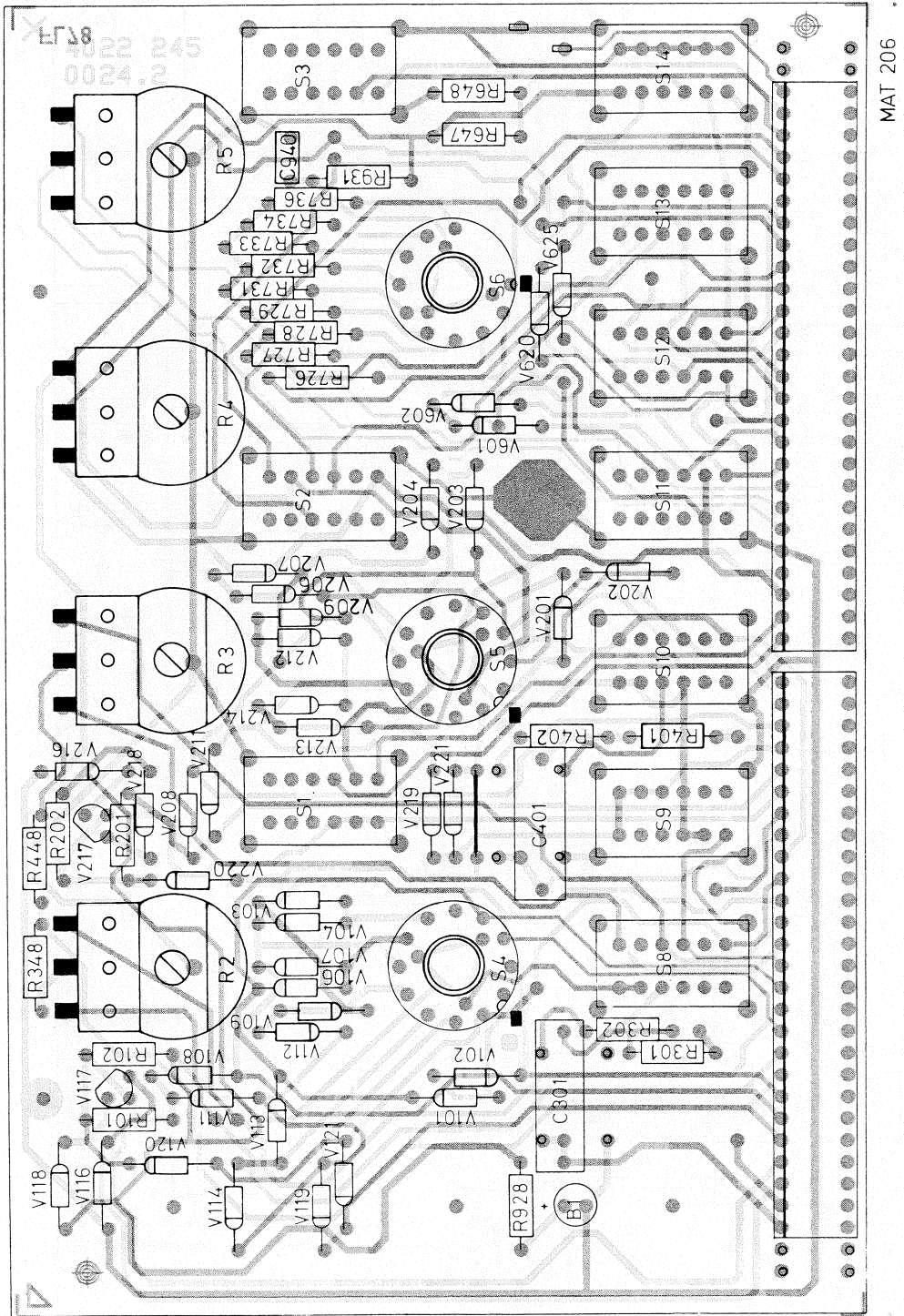

Fig. 12. P.c.b. of Control Unit

MAT 206

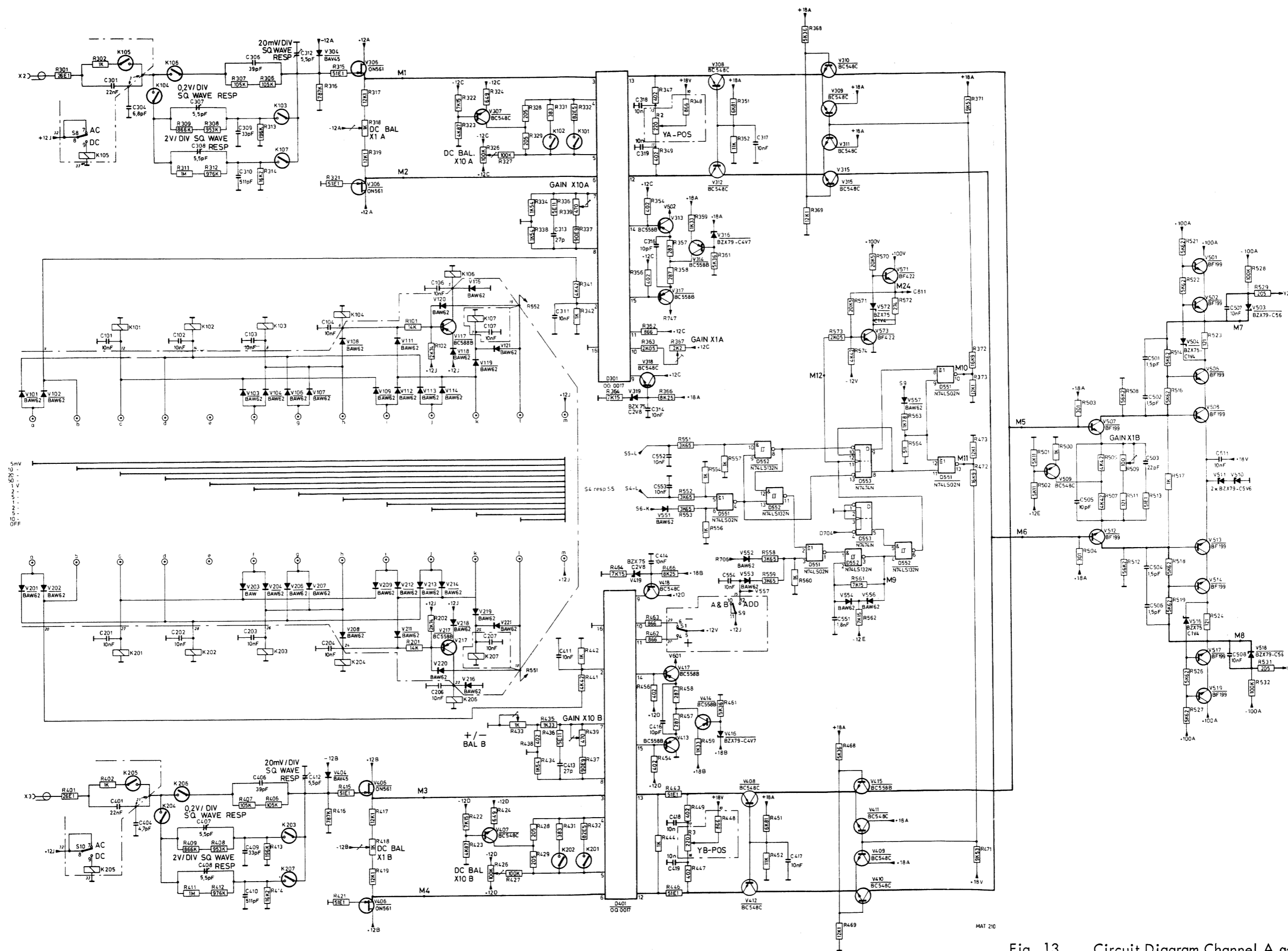

Fig. 13. Circuit Diagram Channel A and B

**CODING SYSTEM OF FAILURE REPORTING FOR QUALITY
ASSESSMENT OF T & M INSTRUMENTS
(excl. potentiometric recorders)**

The information contents of the coded failure description is necessary for our computerized processing of quality data.

Since the reporting of repair and maintenance routines must be complete and exact, we give you an example of a correctly filled-out PHILIPS SERVICE Job sheet.

①	②	③	④																								
Country	Day Month Year	Typenumber /Version	Factory/Serial no.																								
<table border="1" style="display: inline-table; border-collapse: collapse;"> <tr><td style="width: 15px; height: 15px; text-align: center;">3</td><td style="width: 15px; height: 15px; text-align: center;">2</td></tr> </table>	3	2	<table border="1" style="display: inline-table; border-collapse: collapse;"> <tr><td style="width: 15px; height: 15px; text-align: center;">1</td><td style="width: 15px; height: 15px; text-align: center;">5</td><td style="width: 15px; height: 15px; text-align: center;">0</td><td style="width: 15px; height: 15px; text-align: center;">4</td><td style="width: 15px; height: 15px; text-align: center;">7</td><td style="width: 15px; height: 15px; text-align: center;">5</td></tr> </table>	1	5	0	4	7	5	<table border="1" style="display: inline-table; border-collapse: collapse;"> <tr><td style="width: 15px; height: 15px; text-align: center;">O</td><td style="width: 15px; height: 15px; text-align: center;">P</td><td style="width: 15px; height: 15px; text-align: center;">M</td><td style="width: 15px; height: 15px; text-align: center;">3</td><td style="width: 15px; height: 15px; text-align: center;">2</td><td style="width: 15px; height: 15px; text-align: center;">6</td><td style="width: 15px; height: 15px; text-align: center;">0</td><td style="width: 15px; height: 15px; text-align: center;">0</td><td style="width: 15px; height: 15px; text-align: center;">2</td></tr> </table>	O	P	M	3	2	6	0	0	2	<table border="1" style="display: inline-table; border-collapse: collapse;"> <tr><td style="width: 15px; height: 15px; text-align: center;">D</td><td style="width: 15px; height: 15px; text-align: center;">O</td><td style="width: 15px; height: 15px; text-align: center;">0</td><td style="width: 15px; height: 15px; text-align: center;">0</td><td style="width: 15px; height: 15px; text-align: center;">7</td><td style="width: 15px; height: 15px; text-align: center;">8</td><td style="width: 15px; height: 15px; text-align: center;">3</td></tr> </table>	D	O	0	0	7	8	3
3	2																										
1	5	0	4	7	5																						
O	P	M	3	2	6	0	0	2																			
D	O	0	0	7	8	3																					
CODED FAILURE DESCRIPTION																											

⑤	⑥	⑦	⑧																																																																						
Nature of call	Location	Component/sequence no.	Category																																																																						
<table border="1" style="border-collapse: collapse; width: 100%;"> <tr><td style="width: 15px; height: 15px;"></td><td style="width: 100px;">Installation</td><td style="width: 15px; height: 15px;"></td></tr> <tr><td style="width: 15px; height: 15px;"></td><td>Pre sale repair</td><td style="width: 15px; height: 15px;"></td></tr> <tr><td style="width: 15px; height: 15px;"></td><td>Preventive maintenance</td><td style="width: 15px; height: 15px;"></td></tr> <tr><td style="width: 15px; height: 15px; text-align: center;">X</td><td>Corrective maintenance</td><td style="width: 15px; height: 15px;"></td></tr> <tr><td style="width: 15px; height: 15px;"></td><td>Other</td><td style="width: 15px; height: 15px;"></td></tr> </table>		Installation			Pre sale repair			Preventive maintenance		X	Corrective maintenance			Other		<table border="1" style="border-collapse: collapse; width: 100%;"> <tr><td style="width: 15px; height: 15px;"></td><td style="width: 15px; height: 15px;"></td><td style="width: 15px; height: 15px;"></td><td style="width: 15px; height: 15px;"></td></tr> <tr><td style="width: 15px; height: 15px;"></td><td style="width: 15px; height: 15px;"></td><td style="width: 15px; height: 15px;"></td><td style="width: 15px; height: 15px;"></td></tr> <tr><td style="width: 15px; height: 15px; text-align: center;">0</td><td style="width: 15px; height: 15px; text-align: center;">0</td><td style="width: 15px; height: 15px; text-align: center;">2</td><td style="width: 15px; height: 15px; text-align: center;">1</td></tr> <tr><td style="width: 15px; height: 15px;"></td><td style="width: 15px; height: 15px;"></td><td style="width: 15px; height: 15px;"></td><td style="width: 15px; height: 15px;"></td></tr> <tr><td style="width: 15px; height: 15px;"></td><td style="width: 15px; height: 15px;"></td><td style="width: 15px; height: 15px;"></td><td style="width: 15px; height: 15px;"></td></tr> </table>									0	0	2	1									<table border="1" style="border-collapse: collapse; width: 100%;"> <tr><td style="width: 15px; height: 15px; text-align: center;">T</td><td style="width: 15px; height: 15px; text-align: center;">S</td><td style="width: 15px; height: 15px; text-align: center;">0</td><td style="width: 15px; height: 15px; text-align: center;">6</td><td style="width: 15px; height: 15px; text-align: center;">0</td><td style="width: 15px; height: 15px; text-align: center;">7</td></tr> <tr><td style="width: 15px; height: 15px; text-align: center;">R</td><td style="width: 15px; height: 15px; text-align: center;">0</td><td style="width: 15px; height: 15px; text-align: center;">0</td><td style="width: 15px; height: 15px; text-align: center;">6</td><td style="width: 15px; height: 15px; text-align: center;">3</td><td style="width: 15px; height: 15px; text-align: center;">1</td></tr> <tr><td style="width: 15px; height: 15px; text-align: center;">9</td><td style="width: 15px; height: 15px; text-align: center;">9</td><td style="width: 15px; height: 15px; text-align: center;">0</td><td style="width: 15px; height: 15px; text-align: center;">0</td><td style="width: 15px; height: 15px; text-align: center;">0</td><td style="width: 15px; height: 15px; text-align: center;">1</td></tr> <tr><td style="width: 15px; height: 15px;"></td><td style="width: 15px; height: 15px;"></td><td style="width: 15px; height: 15px;"></td><td style="width: 15px; height: 15px;"></td><td style="width: 15px; height: 15px;"></td><td style="width: 15px; height: 15px;"></td></tr> <tr><td style="width: 15px; height: 15px;"></td><td style="width: 15px; height: 15px;"></td><td style="width: 15px; height: 15px;"></td><td style="width: 15px; height: 15px;"></td><td style="width: 15px; height: 15px;"></td><td style="width: 15px; height: 15px;"></td></tr> </table>	T	S	0	6	0	7	R	0	0	6	3	1	9	9	0	0	0	1													<table border="1" style="border-collapse: collapse; width: 100%;"> <tr><td style="width: 15px; height: 15px; text-align: center;">5</td></tr> <tr><td style="width: 15px; height: 15px; text-align: center;">2</td></tr> <tr><td style="width: 15px; height: 15px; text-align: center;">4</td></tr> <tr><td style="width: 15px; height: 15px;"></td></tr> <tr><td style="width: 15px; height: 15px;"></td></tr> </table>	5	2	4		
	Installation																																																																								
	Pre sale repair																																																																								
	Preventive maintenance																																																																								
X	Corrective maintenance																																																																								
	Other																																																																								
0	0	2	1																																																																						
T	S	0	6	0	7																																																																				
R	0	0	6	3	1																																																																				
9	9	0	0	0	1																																																																				
5																																																																									
2																																																																									
4																																																																									
		<input type="checkbox"/> Job completed																																																																							
		<input checked="" type="checkbox"/> Working time																																																																							
		<table border="1" style="display: inline-table; border-collapse: collapse;"> <tr><td style="width: 15px; height: 15px;"></td><td style="width: 15px; height: 15px; text-align: center;">1</td><td style="width: 15px; height: 15px; text-align: center;">2</td></tr> </table> Hrs		1	2																																																																				
	1	2																																																																							

Detailed description of the information to be entered in the various boxes:

① Country:

3	2
---	---

 = Switzerland

② Day Month Year

1	5	0	4	7	5
---	---	---	---	---	---

 = 15 April 1975

③ Type number/Version

O	P	M	3	2	6	0	0	2
---	---	---	---	---	---	---	---	---

 = Oscilloscope PM 3260, version 02 (in later oscilloscopes this number is placed in front of the serial no)

④ Factory/Serial number

D	O	0	0	7	8	3
---	---	---	---	---	---	---

 = DO 783 These data are mentioned on the type plate of the instrument

⑤ Nature of call: Enter a cross in the relevant box

⑥ Coded failure description

<p style="text-align: center;"><i>Location</i></p> <table border="1" style="border-collapse: collapse; width: 100%;"> <tr><td style="width: 15px; height: 15px;"></td><td style="width: 15px; height: 15px;"></td><td style="width: 15px; height: 15px;"></td><td style="width: 15px; height: 15px;"></td></tr> </table> <p>These four boxes are used to isolate the problem area. Write the code of the part in which the fault occurs, e.g. unit no or mechanical item no of this part (refer to 'PARTS LISTS' in the manual). Example: 0001 for Unit 1 000A for Unit A 0075 for item 75 If units are not numbered, do not fill in the four boxes; see Example Job sheet.</p>					<p style="text-align: center;"><i>Component/sequence no.</i></p> <table border="1" style="border-collapse: collapse; width: 100%;"> <tr><td style="width: 15px; height: 15px;"></td><td style="width: 15px; height: 15px;"></td><td style="width: 15px; height: 15px;"></td><td style="width: 15px; height: 15px;"></td><td style="width: 15px; height: 15px;"></td><td style="width: 15px; height: 15px;"></td></tr> </table> <p>These six boxes are intended to pinpoint the faulty component. A. Enter the component designation as used in the circuit diagram. If the designation is alfa-numeric, the letters must be written (starting from the left) in the two left-hand boxes and the figures must be written (in such a way that the last digit occupies the right-most box) in the four right-hand boxes. B. Parts not identified in the circuit diagram: 990000 Unknown/Not applicable 990001 Cabinet or rack (text plate, emblem, grip, rail, graticule, etc.) 990002 Knob (incl. dial knob, cap, etc.) 990003 Probe (only if attached to instrument) 990004 Leads and associated plugs 990005 Holder (valve, transistor, fuse, board, etc.) 990006 Complete unit (p.w. board, h.t. unit, etc.) 990007 Accessory (only those without type number) 990008 Documentation (manual, supplement, etc.) 990009 Foreign object 990099 Miscellaneous</p>							<p style="text-align: center;"><i>Category</i></p> <table border="1" style="border-collapse: collapse; width: 100%;"> <tr><td style="width: 15px; height: 15px;"></td></tr> </table> <p>0 Unknown, not applicable (fault not present, intermittent or disappeared) 1 Software error 2 Readjustment 3 Electrical repair (wiring, solder joint, etc.) 4 Mechanical repair (polishing, filing, remachining, etc.) 5 Replacement (of transistor, resistor, etc.) 6 Cleaning and/or lubrication 7 Operator error 8 Missing items (on pre-sale test) 9 Environmental requirements are not met</p>	

⑦ Job completed: Enter a cross when the job has been completed.

⑧ Working time: Enter the total number of working hours spent in connection with the job (excluding travelling, waiting time, etc.), using the last box for tenths of hours.

	1	2
--	---	---

 = 1,2 working hours (1 h 12 min.)

Sales and service all over the world

Alger: Sadedel; 41 Rue des Frères Mouloud, Alger; tel. 656613-656607

Argentina: Philips Argentina S.A., Casilla Correo 3479, Buenos Aires; tel. 70.7741 al 7749

Australia: Philips Scientific & Industrial Equipment Division, Centre Court, 25-27 Paul Street, P.O. Box 119, North Ryde/NSW 2113; tel. 88 88222

Bangla Desh: Philips Bangla Desh Ltd., P.O. Box 62; Ramna, Dacca, tel. 28332

België/Belgique: S.A. M.B.L.E., Philips Scientific and Industrial Equipment Division; 80 Rue des Deux Gares, 1070 Bruxelles; tel. 2/513.76.00/523.00.00

Bolivia: Industrias Bolivianas Philips S.A., Cajón Postal 2964, La Paz; tel.: 50029/55270/55604

Brasil: S.A. Philips Do Brasil; Avenida 9 de Julho 5229; Caixa Postal 8681; CEP 01407 - São Paulo (S.P.); tel. 282-5722/282-1611

Burundi: Philips S.A.R.L., Avenue de Grèce, B.P. 900, Bujumbura

Canada: Philips Test and Measuring Instruments Inc.; 6 Leswyn Road, Toronto (Ontario) M6A-1K2; tel. (416) 789-7188

Chile: Philips Chilena S.A., Casilla 2687, Santiago de Chile; tel. 394001/770038

Colombia: Industrias Philips de Columbia S.A., Calle 13 no. 51-03, Apartado Aéreo 4282, Bogotá; tel. 611877

Costa Rica: Philips de Costa Rica Ltd., Apartado Postal 4325, San José; tel. 210111

Danmark: Philips Elektronik Systemer A/S, Afd. for Industri og Forskning; Strandlodsvej 4, P.O. Box 1919, 2300 København S; tel. 01-57-2222; telex 27045

Deutschland (Bundesrepublik): Philips GmbH, Unternehmensbereich Elektronik für Wissenschaft und Industrie, Postfach 310 320; 35 Kassel-Bettenhausen, Miramstrasse 87; tel. 561-5011

Ecuador: Philips Ecuador S.A., Casilla 343, Quito; tel. 239080

Egypt: Ph. Scientific Bureau, 5 Sherif Str., Cairo - A.R. Egypt, P.O. Box 1687; tel. 78457-57739-914293

Eire: Philips Electrical (Ireland) Ltd., Newstead, Clonskeagh, Dublin 14; tel. 693355

El Salvador: Philips de El Salvador S.A., Apartado Postal 865, San Salvador; tel. 21-7441

España: Philips Ibérica S.A.E., Dpto Aparatos de Medida, Martinez Villergas 2, Apartado 2065, Madrid 27; tel. 404-2200/3200/4200

Ethiopia: Philips Ethiopia (Priv. Ltd. Co.), P.O.B. 2565; Ras Abebe Areguay Avenue, Addis Ababa; tel. 13440

Finland: See Suomi

France: S.A. Philips Division S&I, Division de la S.A. Philips Industrielle et Commerciale, 105 Rue de Paris, 93 002 Bobigny; tel. 830-11-11

Ghana: Philips (Ghana) Ltd., P.O.B. M 14, Accra; tel. 66019

Great Britain: Pye Unicam Ltd, York Street, Cambridge CB1-2PX; tel. (0223) 58866
Service Centre:
Pye Unicam Ltd.,
Beddington Lane, Croydon, Surrey CR9-4EN; tel. 01-684-3670

Greece: See Hellas

Guatemala: Philips de Guatemala S.A., Apartado Postal 238, Ciudad de Guatemala, Zona 9; tel. 64857

Hellas: Philips S.A. Hellénique, 54 Avenue Syngrou, Athens 403; P.O. Box 153; tel. 9215311

Hong Kong: Philips Hong Kong Ltd., P.O.B. 2108, St. George's Building, 21st floor, Hong Kong city; tel. 5-249246

India: Philips India Ltd., Shivsagar Estate, Block "A", Dr. Annie Besant Road, P.O.B. 6598, Worli, Bombay 18; tel. 370071/391431

Indonesia: P.T. Philips Development Corporation Jalan Proklamasi 33, P.O.B. 2287, Jakarta; tel. 51985/51986/81876

Iran: Philips Iran Ltd., P.O.B. 1297, Teheran; tel. 662281-5

Iraq: Philips Iraq W.L.L., Munir Abbas Building, 4th floor; South Gate, P.O. box 5749, Baghdad; tel. 80409/98844

Island: Heimilsteaki SF, Saetun 8, Reykjavik; tel. 24000

Islas Canarias: Philips Ibérica S.A.E., Triana 132, Las Palmas, Casilla 39-41, Santa Cruz de Tenerife

Italia: Philips S.p.A., Sezione S&I, Viale Etvezia 2, 20052 Monza; tel. 36351, telex M: 35290

Japan: See Nippon

Kenya: Philips (Kenya) Ltd., P.O.B. 30554, Nairobi; tel. 29981

Kuwait: Delegate Office of Philips Industries, P.O.Box 3801; Kuwait; tel. 33814

Malaysia: Philips Malaya Sdn Bhd., P.O. Box 2163, Petaling Jaya, Kuala Lumpur; Selangor, W. Malaya; tel. 774411

México: Philips Mexicana S.A. de C.V., Calle Durango 167, Div. Científico Industrial, Apartado Postal 24-328 Mexico 7 (D.F.); tel. 525 15 40

Morocco: Samtel 2 Rue de Bapaume, Casablanca; tel. 243050-243052

Nederland: Philips Nederland B.V., Hoofdgroep PPS, Boschdijk 525, Gebouw VB, Eindhoven; tel. 793333

Ned. Antillen: Philips Antillana N.V., Postbus 523, Willemstad, Curaçao; tel. 37575-35464

New Zealand: Philips Electrical Industries of N.Z. Ltd., Scientific and Industrial Equipment Division Wakefield Street 181-195, P.O.B. 2097, Wellington; tel. 859-859

Nigeria: Philips (Nigeria) Ltd., 6 Ijora Causeway, P.O.B. 1921, Lagos; tel. 45414/7

Nippon: Nihon Philips Corporation, Shuwa Shinagawa Building, 26-33 Takanawa 3 - Chome, Minato-Ku, Tokyo 108; P.O. Box 13; tel. (03) 448-5574

Norge: Norsk A.S. Philips, Industri og Forsking, Essendrops gate 5, Postboks 5040, Oslo 3; tel. 463890

Osterreich: Oesterreichische Philips Industrie GmbH, Abteilung Industrie Elektronik, Breitenfurterstrasse 219, A-1230 Wien; tel. (222)-831501/05

Pakistan: Philips Electrical Co. of Pakistan Ltd., El-Markaz, M.A. Jinnah Road, P.O.B. 7101, Karachi 3; tel. 70071

Paraguay: Philips del Paraguay S.A., Casilla de Correo 605, Asunción; tel. 48045-46919

Perú: Philips Peruana S.A., Apartado Aéreo 1841, Lima 5; tel. 326070

Philippines: Philips Industrial Development Inc., 2246 Pasong Tamo, P.O.B. 911, Makati Rizal D-708; tel. 889453 to 889456; 868951

Portugal: Philips Portuguesa S.A.R.L., Av. Eng. Duarte Pacheco 6, Apartado 1331, Lisboa 1; tel. 683121/9

Rwanda: Philips Rwanda S.A.R.L., B.P. 449, Kigali.

Saudi Arabia: A. Rajab and A. Silsilah, P.O. Box 203, Jeddah - Saudi Arabia; tel. 27392/5

Schweiz-Suisse-Svizzera: Philips A.G., Binzstrasse 15, Postfach 307, Ch 8027 Zurich; tel. 442211

Singapore: Philips Singapore Private Ltd., P.O. Box 340, Toa Payoh Central Post Office; Singapore 12; tel. 538811

South Afrika: South African Philips (Pty) Ltd., P.O.B. 7703, 2 Herb Street, New Doornfontein, Johannesburg 2000; tel. 240531

South-Korea: Philips Electronics (Korea) Ltd., P.O. Box 3680, Seoul; tel. 737222

Suomi: Oy Philips Ab., Kaivokatu 8, P.O. Box 10255, 00101 Helsinki 10; tel. 17271

Sverige: Svenska A.B. Philips, Philips Industri Elektronik, Lidingövägen 50, Fack, S10250 Stockholm; tel. 635000

Syria: Philips Moven-Orient S.A., Rue Fardoss 79, Immeuble Kassar and Sadate, B.P. 2442, Damas; tel. 18605-21650

Taiwan: Philips Taiwan Ltd., San Min Building, P.O. Box 22978, Taipei

Tanzania: Philips (Tanzania) Ltd., Box 20104, Dar es Salaam; tel. 29571

Thailand: Philips Electrical Co. of Thailand Ltd., 283 Silom Road, P.O. Box 961, Bangkok; tel. 233-6330

Tunisia: S.T.I.E.T., 32815, Rue Ben Ghedhahem, Tunis; tel. 244268

Türkiye: Türk Philips Ticaret A.S., Posta Kutusa 504, Beyoglu, Gümüssüyu Caddesi 7880, Istanbul 1; tel. 435910

Uganda: Philips Uganda Ltd., P.O. Box 5300, Kampala; tel. 59039

Uruguay: Industrias Philips del Uruguay S.A., Avda Uruguay 1287, Casilla de Correo 294, Montevideo; tel. 915641/44

U.S.A.: Philips Test and Measuring Instruments Inc. 85, Mc Kee Drive, Mahwah, New Jersey 07430, tel. (201) 529-3800

Venezuela: Industrias Venezolanas Philips S.A., Apartado Aéreo 1167, Caracas 107; tel. 360511/363011/362255

Zaire: Philips S.Z.R.L., B.P. 1798, Kinshasa; tel. 31887-31888-31693-31208

Zambia: Philips Electrical Ltd., Professional Equipment Division, P.O.B. 553; Kitwe; tel. 2526/78

T&M/78050

For information on change of address:
N.V. Philips Gloeilampenfabrieken
Test and Measuring Instruments Dept.
Eindhoven - The Netherlands

For countries not listed:
N.V. Philips S&I Export Dept.
Test and Measuring Instruments Dept.
Eindhoven - The Netherlands